

Air/water/tank 6kw 9kw Split Heat Pump

User's Manual



Before operating this product, please read the instructions carefully and keep this manual for future use.

Catalogue

Before use

1

1. List of accessories	1
2. Safety precautions	2
3. Main components	6
4. Outlines and dimensions	9
5. Working principles	12
6. Specifications	12
7. Exploded view	14

Installation

16

1. Installation methods	20
2. Installation of the indoor unit	22
3. Installation of the outdoor unit	23
3.1 Installation notes	23
3.2 Installation	24
4. Wiring	25
4.1 Power cable between indoor and outdoor unit	25
4.2 Wiring of 6kW electric heater	27
5. Refrigerant pipe connection	29
6. Water pipe connection	31
7. Installation of the kits	33
7.1 T/P valve	33
7.2 Automatic air vent valve	34
7.3 Water pressure gauge	34
8. Water temperature sensor	35
9. Air purging of water system	36
10. Pre-Start up	38
10.1 Check before pre-start up	38
10.2 Pre-start up	38

Use

35

1. Introduction of wired controller	39
2. Operation on wired controller	40
3. Error code	47
4. Electric heater	49
4.1 1.7KW electric heater	49
4.2 6KW electric heater	50

Service and maintenance

51

1. Attention	51
2. Service	52
2.1 Indoor unit	52
2.2 Outdoor unit	52
3. Maintenance	53
3.1 Cleaning of water filter	53
3.2 Cleaning of heat exchanger	53
3.3 Gas charging	53
3.4 Anti-freezing in winter	54
4. Troubleshooting	55

Wiring diagram

57

Before use



Attention









Thank you for choosing the product. In order to operate this product well and to prevent accidents due to misoperation, please read carefully this user manual before carrying out any installation or operation. Please pay special attention to the warning, prohibition and attention instructions. We will continuously upgrade this user manual for better service!

1. List of accessories

The accessories below are delivered together with the product .



Please check in time. If there is any shortage or damage, please contact local distributor.

【INDOOR UNIT】

Name	Quantity	Remark
User Manual	1 piece	 Instruction of installation and operation
Rubber Absorber	3 piece	 absorbing the vibration of indoor unit
One Way Valve	1 piece	 To be installed on city water inlet
T/P Valve	1 piece	 To be installed under indoor unit, For safety of the system
Water Pressure Gauge	1 piece	 To read water pressure
Automatic Air Vent	1 piece	 For releasing air
Connector (3/4" to 1/2")	1 piece	 Connect to automatic air vent valve
Piping kit with connector	1 set	 together

For connecting indoor and outdoor unit

【OUTDOOR UNIT】

Name	Quantity	Remark
Installation Bracket	2 piece	 For mounting outdoor unit to the wall
Rubber Absorber	4 piece	 For absorbing the vibration of outdoor unit

Before use

The following signs are very important. Please be sure to understand their meaning, which concerns the product and your personal safety.

 Warning

 Caution

 Prohibition

2. Safety precautions



This appliance is not intended for use by persons, including children, with reduced physical, sensory or mental capabilities, or lack of experience and knowledge, unless they have been given supervision or instruction concerning use of the appliance by a person responsible for their safety. Children should be supervised to ensure that they do not play with the appliance.

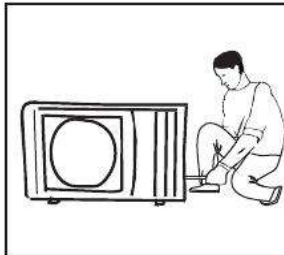

The installation, dismantlement and maintenance of the unit must be performed by qualified personnel. It is forbidden to do any changes to the structure of the unit. Otherwise injury of person or unit damage might happen.

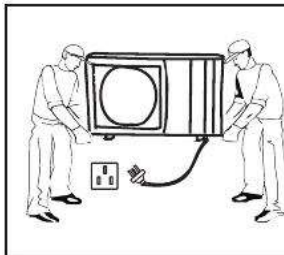

Make sure the power supply to the heat pump unit is off before any operations are done on the unit. When the power cord gets loose or is damaged, always get a qualified person to fix it.

Before use

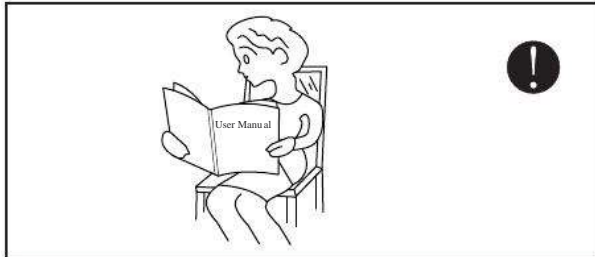

Be sure to read this manual before use.

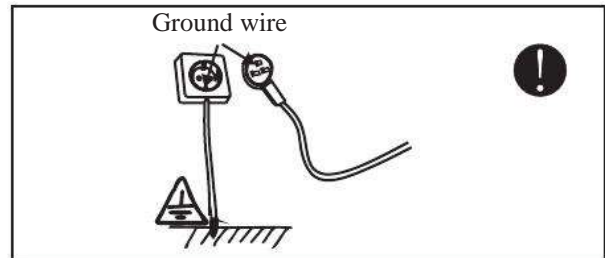

The power supply to the unit must be grounded.

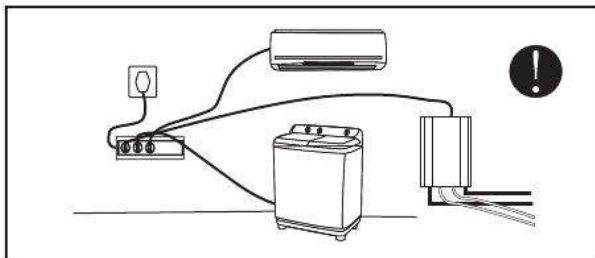

Use a dedicated socket for this unit, otherwise malfunction may occur.

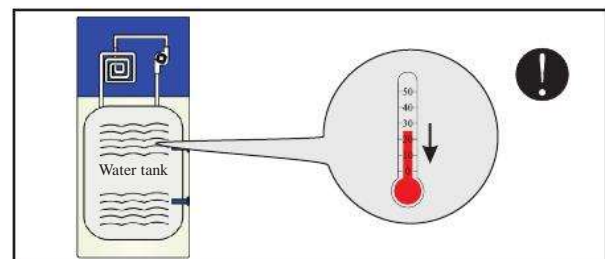

Don't run the heat pump unit with water temperature lower than 25°C.

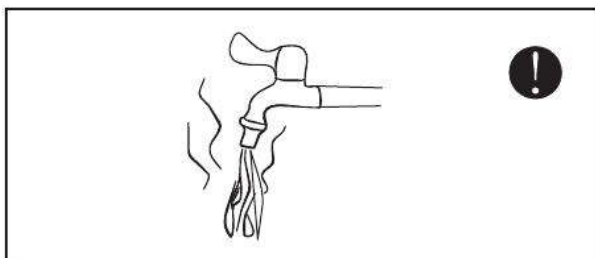

For taking shower, please always add a mixture valve before water tap and set it to proper temperature. Make sure not get burned by the hot water.

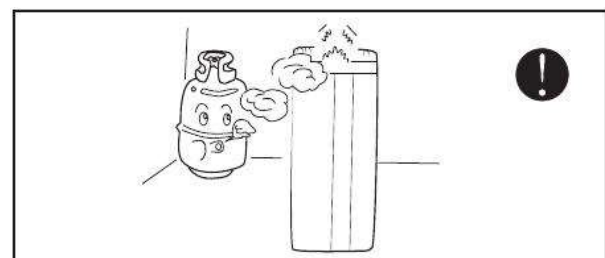

Keep the unit away from the combustible or corrosive environment.

Before use

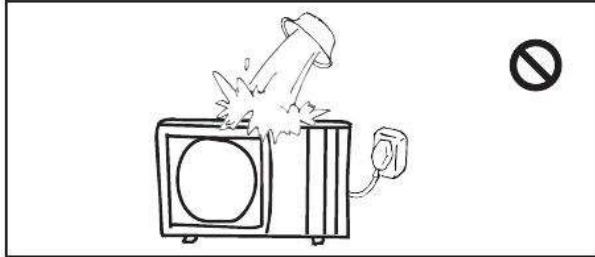

Water or any kind of liquid is strictly forbidden to be poured into the product, it may cause creepage or breakdown of the product.

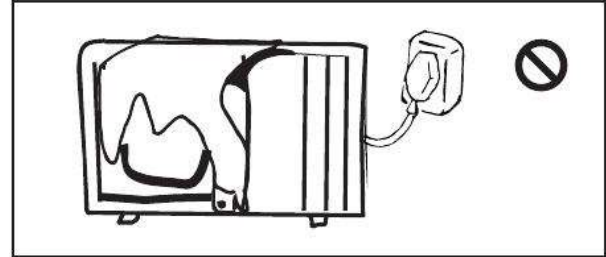

even non-operation of this unit. When running the unit, never cover the

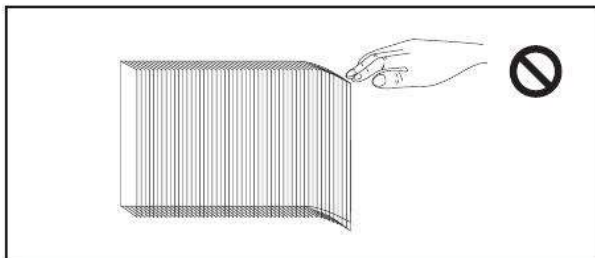

Be aware finger might be hurt by the fin of the coil.

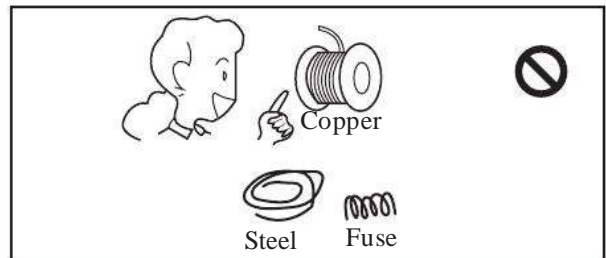

Please select the correct fuse or breaker as per recommended. Steel wire or copper wire cannot be used as substitute for fuse or breaker. Otherwise, damages maybe caused.

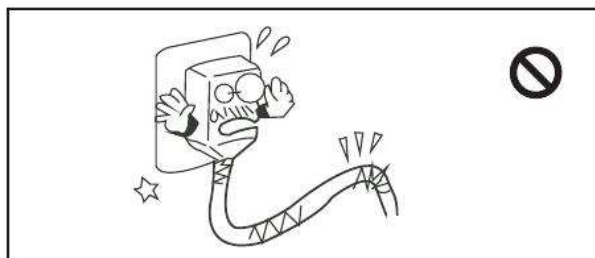

When the power cord gets loose or is damaged, always get a qualified person to fix it.

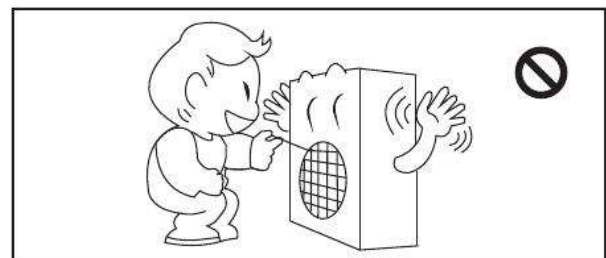

Do not touch the air outlet grill when fan motor is running.

Before use

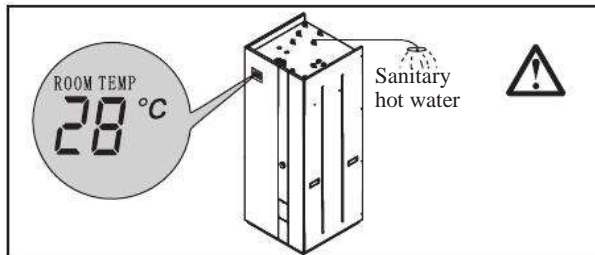

Please mind that when the unit works in room temperature control mode, it may not supply sanitary hot water, with enough high temperature.

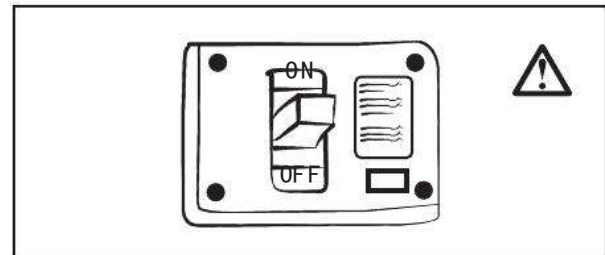

be damaged.
It is mandatory to use a suitable

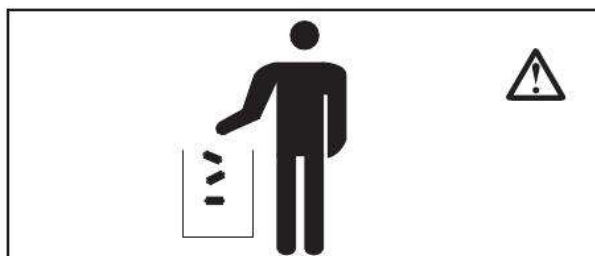

Disposal of Scrap Batteries --- Please discard the batteries as sorted municipal waste at the accessible collection point.

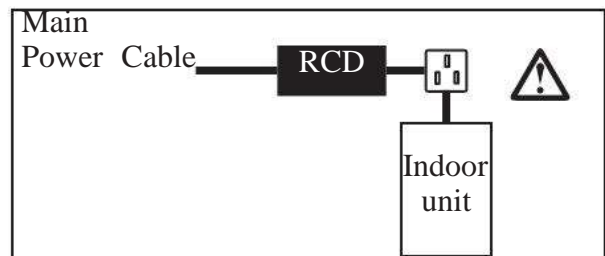

Installation of a residual current device (RCD) having a rated residual operating current not exceeding 30 mA is advisable

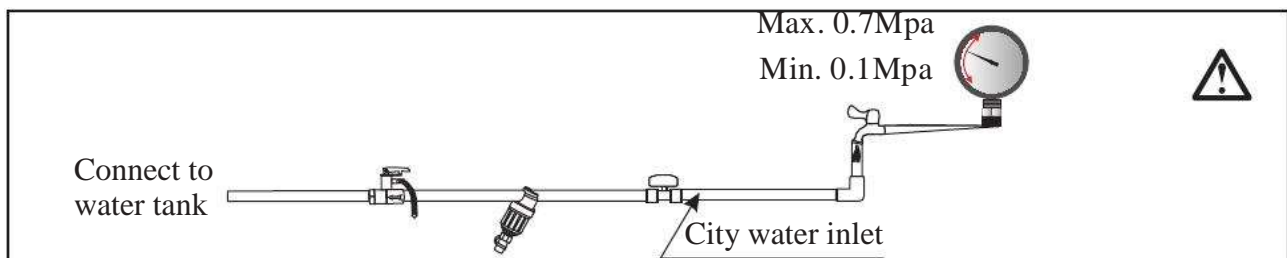

The maximum inlet water pressure, in pascals: 0.7Mpa.
The minimum inlet water pressure, in pascals, if this is necessary for the correct operation of the appliance: 0.1Mpa.

Before use

3. Main components

【6kw Indoor unit】

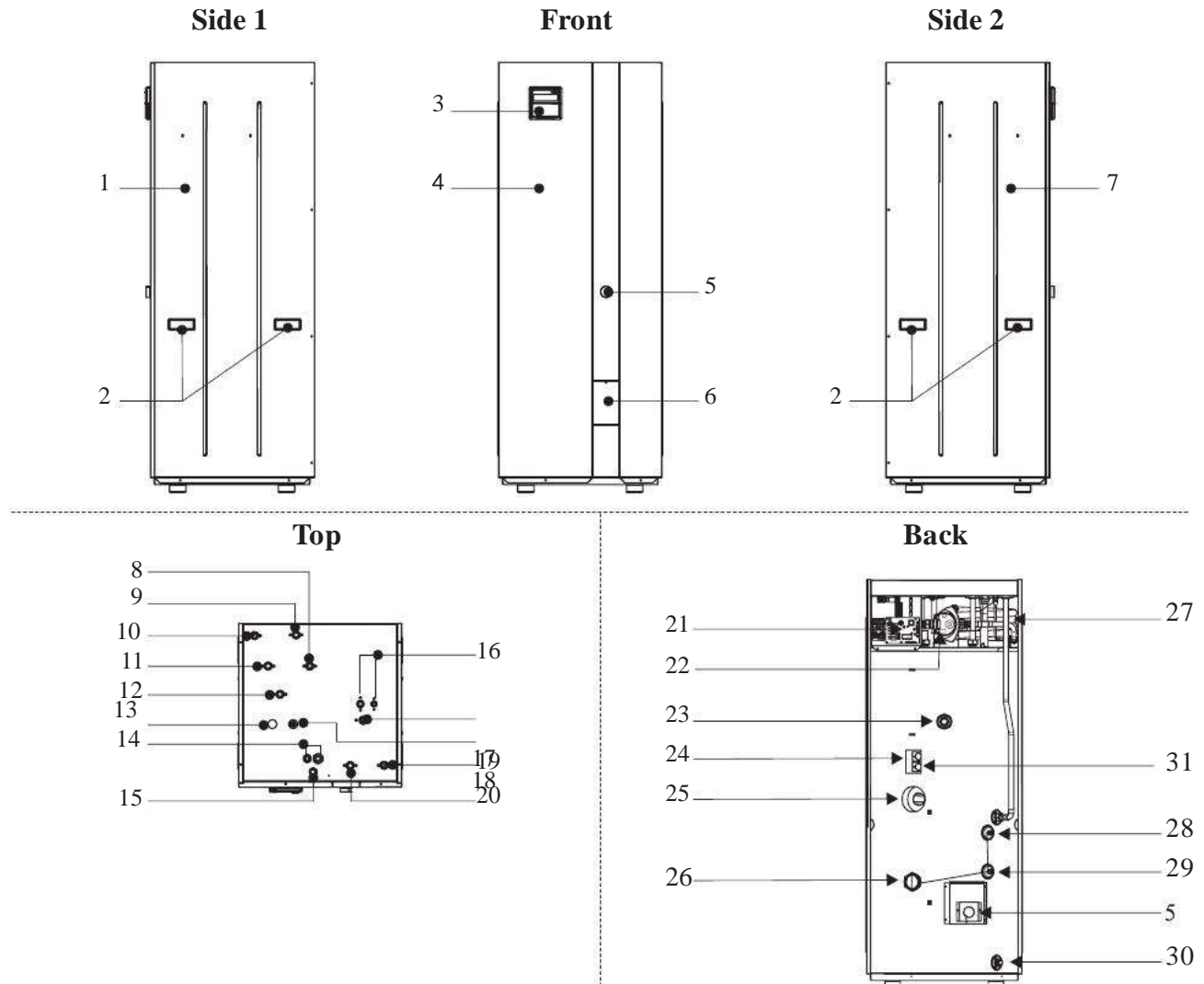

NO.	NAME
1	Right Panel
2	Handle
3	Wired Controller
4	Front Panel
5	Thermostat 1
6	Front panel 2b
7	Left panel
8	High Level Water Outlet
9	City Water Inlet
10	Shower Coil Water Inlet
11	Water from Floor Heating/Radiator
12	Mid / Lower Level Water Outlet
13	Water Pressure Gauge
14	Power Supply
15	Cable Gland
16	Refrigerant Connector

NO.	NAME
17	Automatic Air Vent Valve
18	T/P Valve
19	Water Outlet to Radiator
20	Water Outlet to Floor Heating
21	P.C.B
22	Water pump
23	Anode rod
24	Overheating protector for 1.7KW electric heater
25	1.7KW electric heater 230V/50Hz/1PH
26	6KW electric heater 400V/50Hz/3Ph(can be 230V/50Hz/3ph by change the wiring)
27	Plate heat exchanger
28	Temperature sensor 2
29	Temperature sensor 1
30	Drainage
31	Overheating protector for 6KW electric heater

Before use

【9KW Indoor unit】

Outside

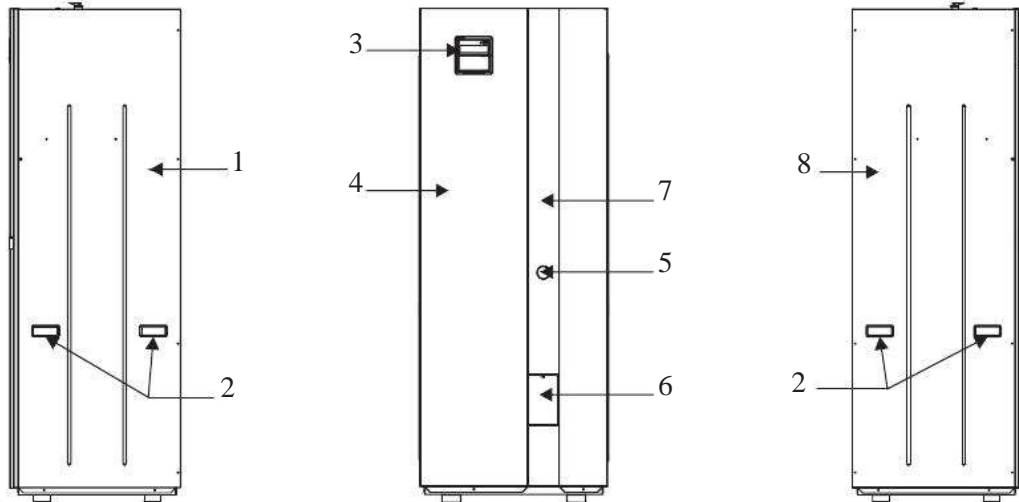

Top

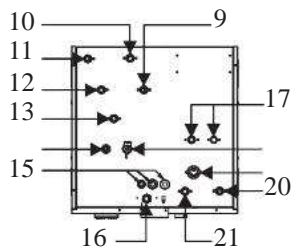

Inside

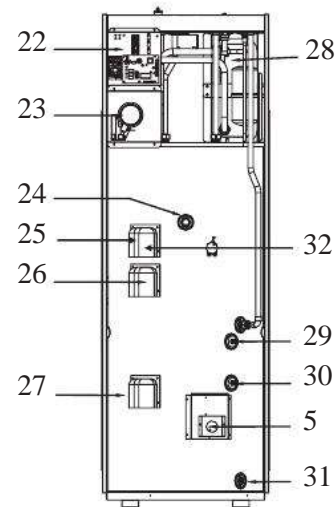

NO.	Name
1	Right panel
2	Handle
3	Wired controller
4	Front panel
5	Thermostat 1
6	Small front panel
7	Decorative panel
8	Left panel
9	High temperature shower water outlet
10	Filling of tank/heating system
11	Shower coil water inlet
12	
13	Middle temperature shower water outlet
14	Manometer
15	Power supply
16	Connector for power cable to outdoor unit
17	Connector for piping kit

NO.	Name
18	T/P valve
19	Automatic exhaust valve
20	Water outlet to radiator
21	Water outlet to floor heating
22	
23	Water pump
24	Anode rod
25	Overheating protector for 1.7KW electric heater
26	
27	6KW electric heater 400V/50Hz/3Ph(can be 230V/50Hz/3ph by change the wiring)
28	Plate heat exchanger
29	Temperature sensor 2
30	Temperature sensor 1
31	Drainage
32	Overheating protector for 6KW electric heater

Before use

【6KW Outdoor unit】

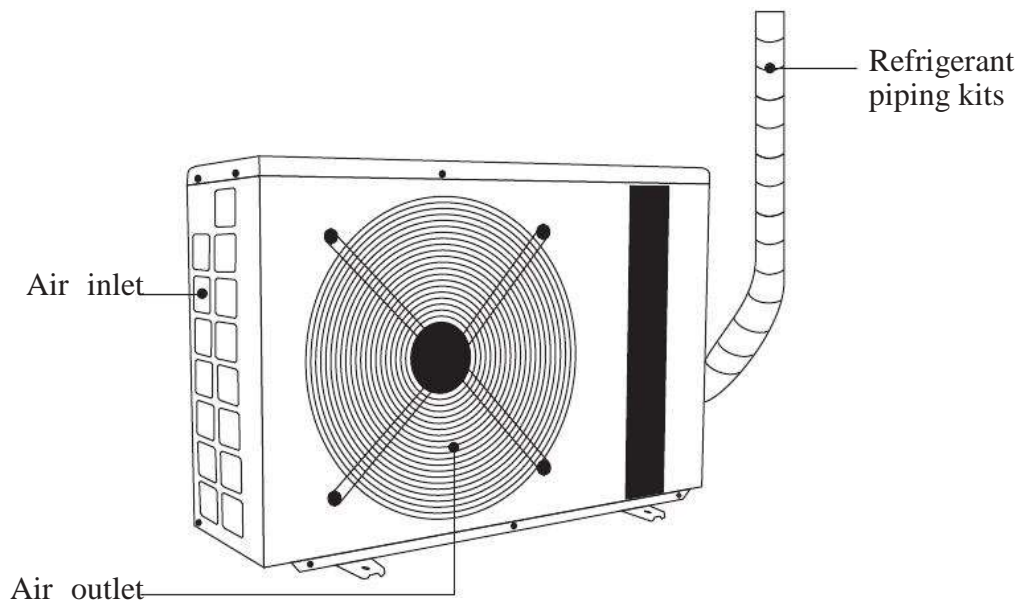

【9KW Outdoor unit】

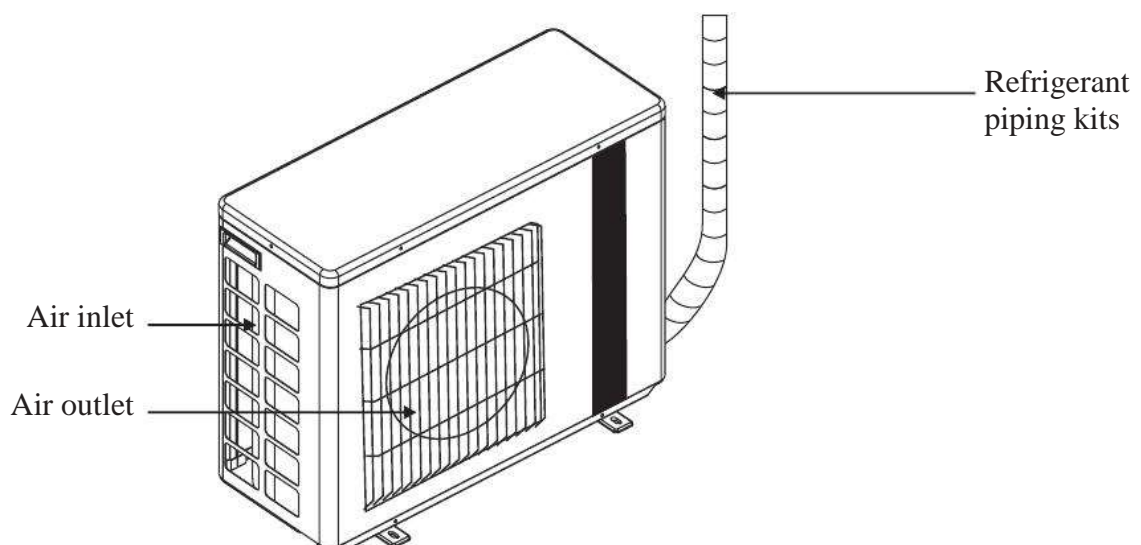

4. Outlines and dimensions

【6KW Indoor unit】

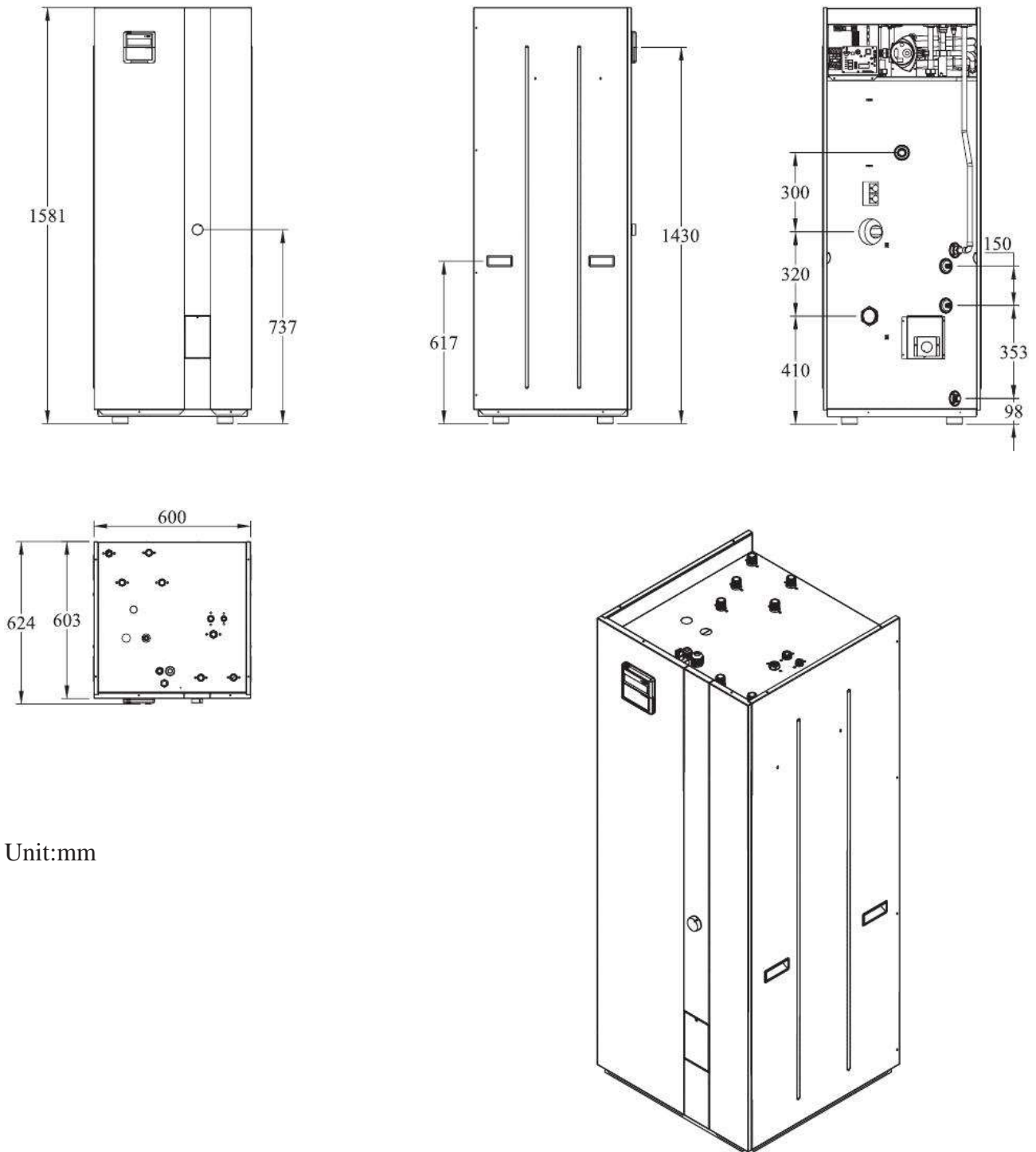

Unit:mm

Before use

【11KW Indoor unit】

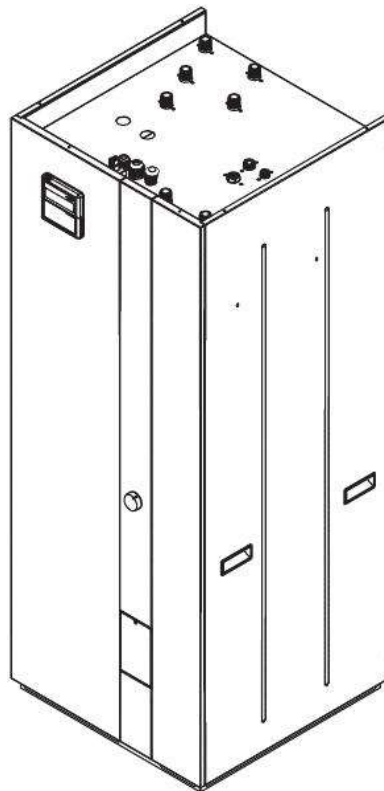
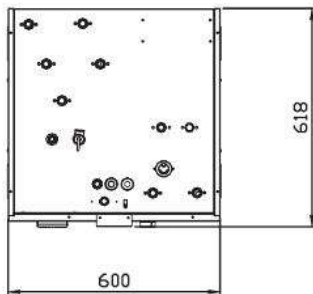
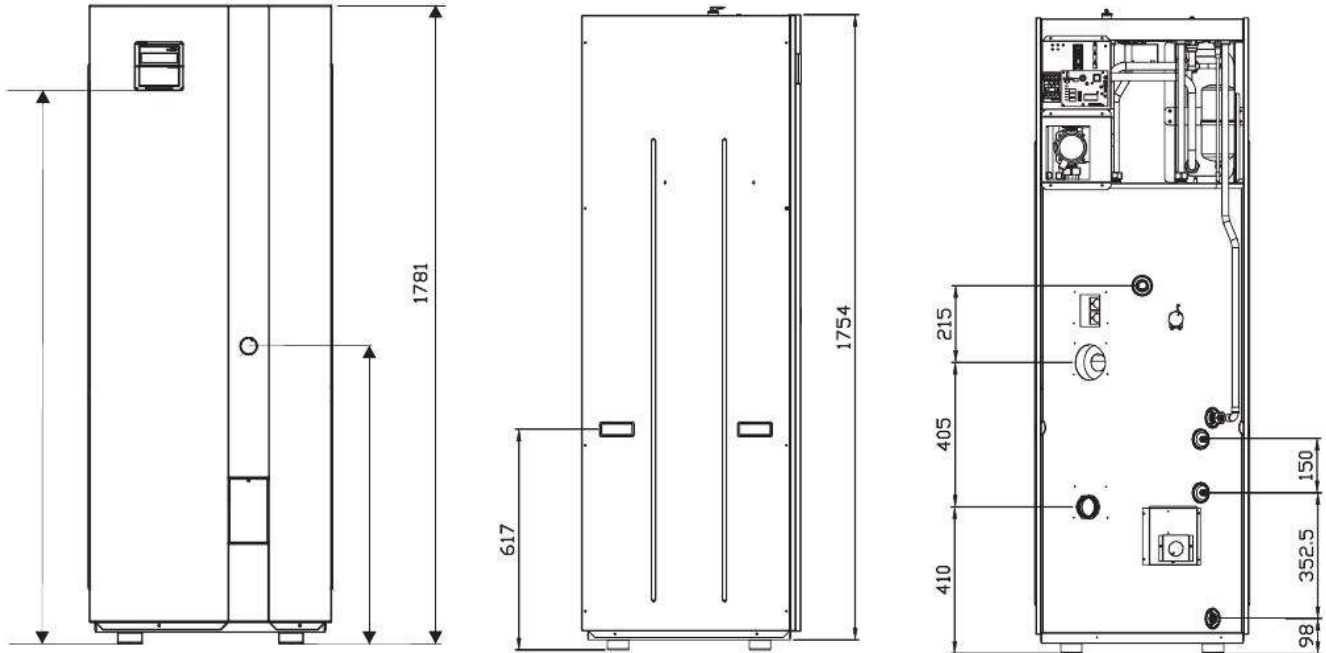

Before use

【6KW Outdoor unit】

Unit:mm

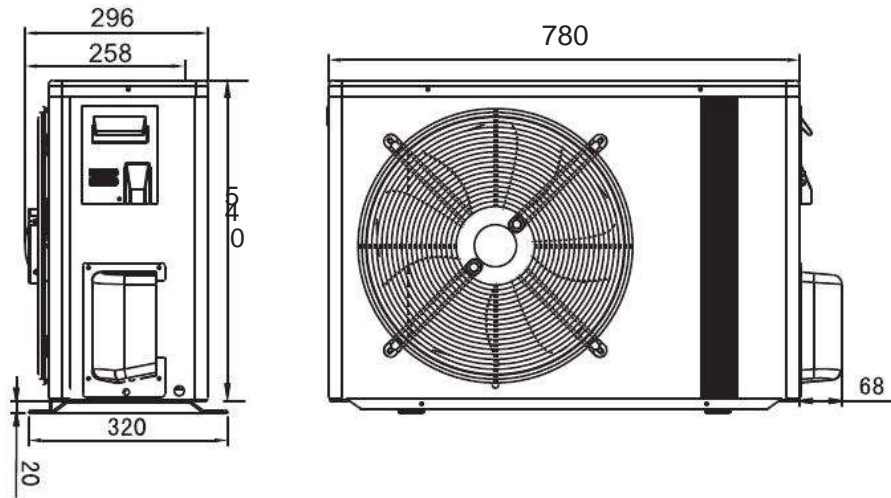

Liquid pipe O.D. $\phi 6.35(1/4")$
 Gas pipe O.D. $\phi 12.7(1/2")$

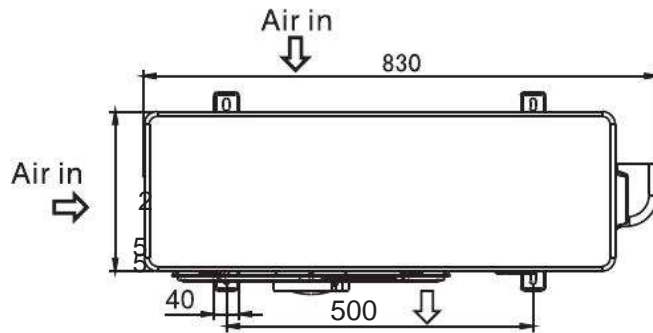

【9KW Outdoor unit】

Unit:mm

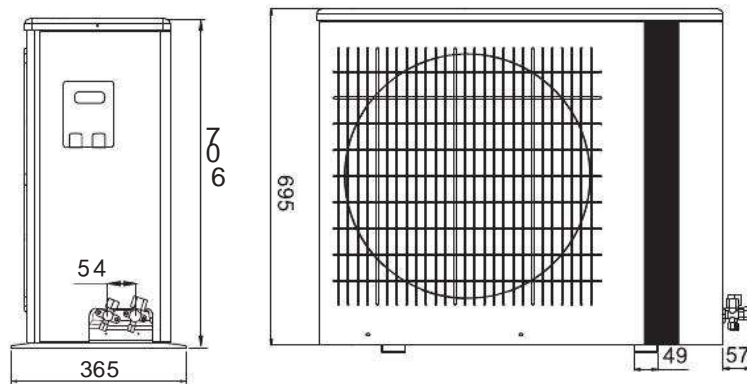

Liquid pipe O.D. $\phi 9.52(3/8")$
 Gas pipe O.D. $\phi 12.7(1/2")$

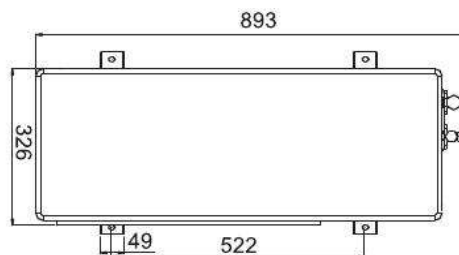

Before use

5. Working principles

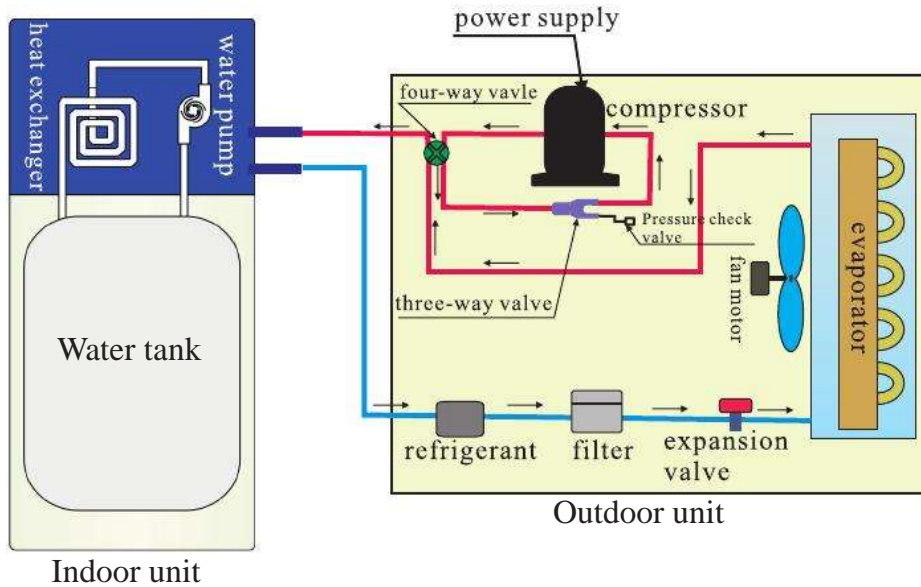

6. Specifications

Indoor unit				
Model number			PAVH-12D1DD-200L	PAVH-24D1DD-200L
Power supply			230V/50Hz/1PH	230V/50Hz/1PH
1.7KW Electric Heater			230V/50Hz/1PH	230V/50Hz/1PH
6KW Electric Heater			400V/50Hz/3PH or 230V/50Hz/3PH	
Water side Heat Exchanger	Type		Tube-in-tube heat exchanger	Plate heat exchanger
	Water pressure drop	Kpa	30	30
	Piping-connection	Inch	G3/4"	G1"
	Water head	M	6	6
	Rated water flow	m/h	1.0	3.0
Max. Water Temp.		°C	75	75
Tank Volume		L	200	200L
Refrigerant	Indoor unit		R410A	R410A
	Piping kits		R410A	R410A
Net dimension		mm	600×600×1580	615×600×1780
Packing dimension		mm	655×640×1730	655×655×2080
Net weight		Kg	120	130
Gross weight		Kg	135	145

Before use

Outdoor unit				
Model number			PAVH-12D1DD-200L	PAVH-24D1DD-200L
Power supply			230V/50HZ/1PH	230V/50HZ/1PH
Refrigerant			R410A	R410A
Heating capacity		Btu/h	7165-20472	15582-39238
		W	2100-6000	4567-11500
Input power (Heating)		W	500-1500	915-3028
Input current (Heating)		A	2.2-6.5	4.0-13.17
C.O.P		W/W	3.3-4.2	3.8-5.1
Compressor	Type		Inverter rotary	Twin rotary
	Quantity	Pcs	1	1
Fan	Type		Axial	Axial
	Quantity	Pcs	1	1
	Airflow	M/h	1750	3200
	Input power	W	85	160
Air side Heat Exchanger	Type		Tube-Fin	Tube-Fin
	Face area	M	0.395	0.871
	Row-Fins/in		2 Rows-14	2 Rows-14
	Tube Diameter	Inch	3/8"	3/8"
Noise		DB(A)	46	55
Net dimension		mm	780×255×590	1044×414×763
Packing dimension		mm	920×340×600	1140×480×805
Net weight		Kg	33	70
Gross weight		Kg	36	72.5

Technical specification	
Ambient temperature range in heating	-25-45°C
Outlet water temperature range in heating	25-52°C
Max refrigerant pipe length (single return)	10m
Max height difference between indoor and outdoor unit	5m
Refrigerant pipe dimension	Liquid pipe OD 12.7(1/2"), Gas pipe OD pipe 6.35(1/4")

3

Installation advice	
Max allowable water pressure	0.7 Mpa
Max setting temperature	52°C
Max outlet water temperature at ambient temperature -15°C	52°C

Note:

Heating condition: Water in/out temperature: 30°C/35°C, ambient temperature: DB/WB 7/6°C.

The specifications are subject to change without prior notice.

For actual specifications of the unit, please refer to the specification stickers on the unit.

7. Exploded view

【6kw Indoor unit】

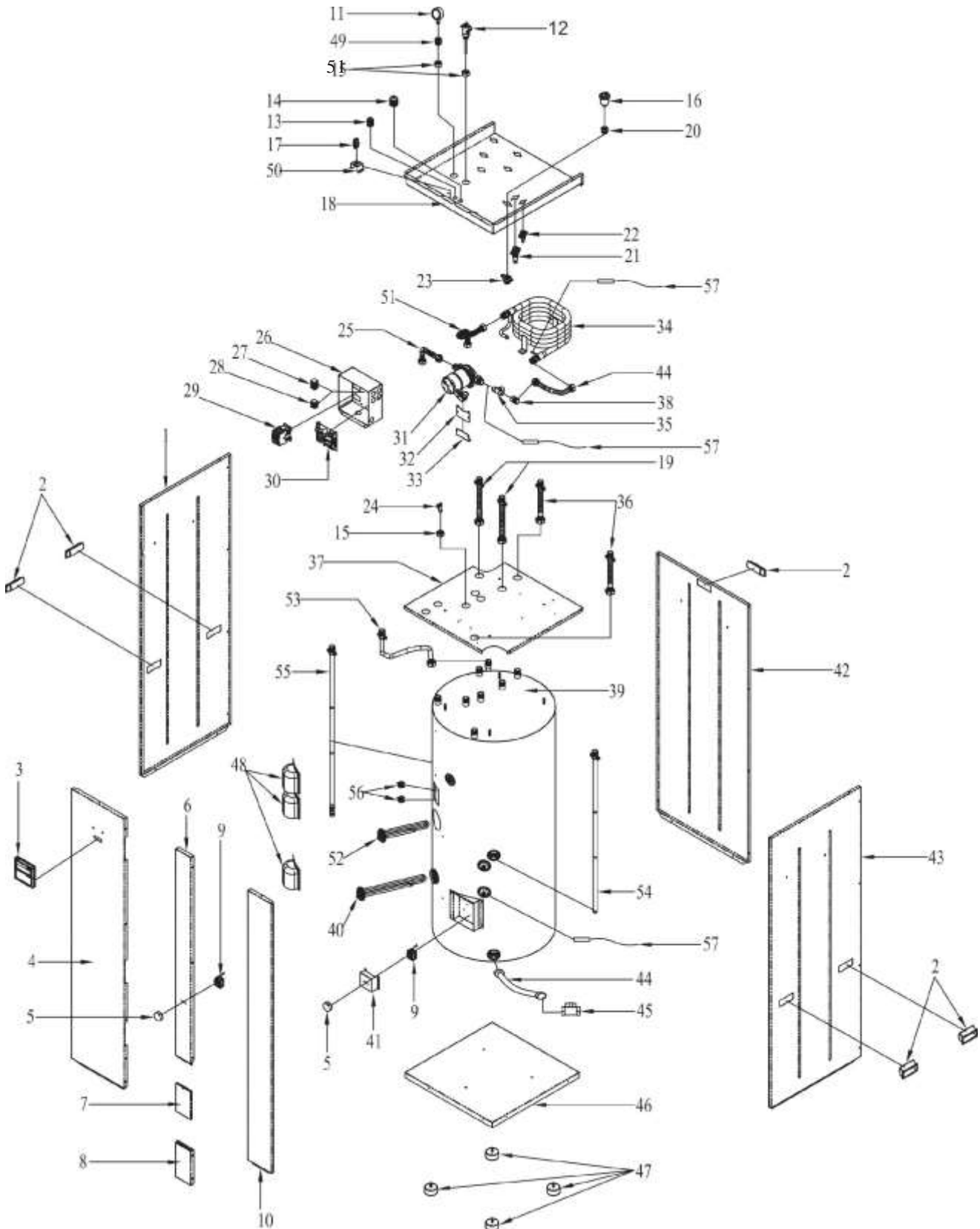

Before use

No.	Name	Quantity	No.	Name	Quantity
1	Left panel	1	27	4-position terminal block	1
2	Handle	5	28	3-position terminal block	1
3	Wired controller	1	29	AC contactor	1
4	Front panel 1	1	30	Controller	1
5	Thermostat knob	2	31	Water pump	1
6	Front panel 2a	1	32	Water pump bracket 1	1
7	Front panel 2b	1	33	Water pump bracket 2	1
8	Front panel 2c	1	34	Tube in tube heat exchanger	1
9	Thermostat	2	35	T valve	1
10	Front panel 3	1	36	Brass fittings	6
11	Water pressure gauge	1	37	Middle plate	1
12	T/P valve	1	38	G3/4" Copper nut	3
13	Cable gland PG16	1	39	Water tank	1
14	Cable gland PG21	1	40	Electric heater	1
15	G1/2" Copper nut	3	41	Thermostat bracket	1
16	Automatic air vent valve	1	42	Back panel	1
17	Cable gland	1	43	Right panel	1
18	Top panel	1	44	Stainless steel hose 1	1
19	Connector	7	45	Ball Valve	1
20	Connector adaptor 1	1	46	Bottom plate	1
21	1/2" gas valve	1	47	Rubber feet	4
22	1/4" liquid valve	1	48	Thermostat 2	1
23	Connector adaptor 2	1	49	Connector adaptor for water pressure gauge	1
24	T valve 2	1	50	Stainless steel hose 2	1
25	Copper pipe	3	51	G1/2" female connector	2
26	Electrical box	1			

Before use

【9kw Indoor unit】

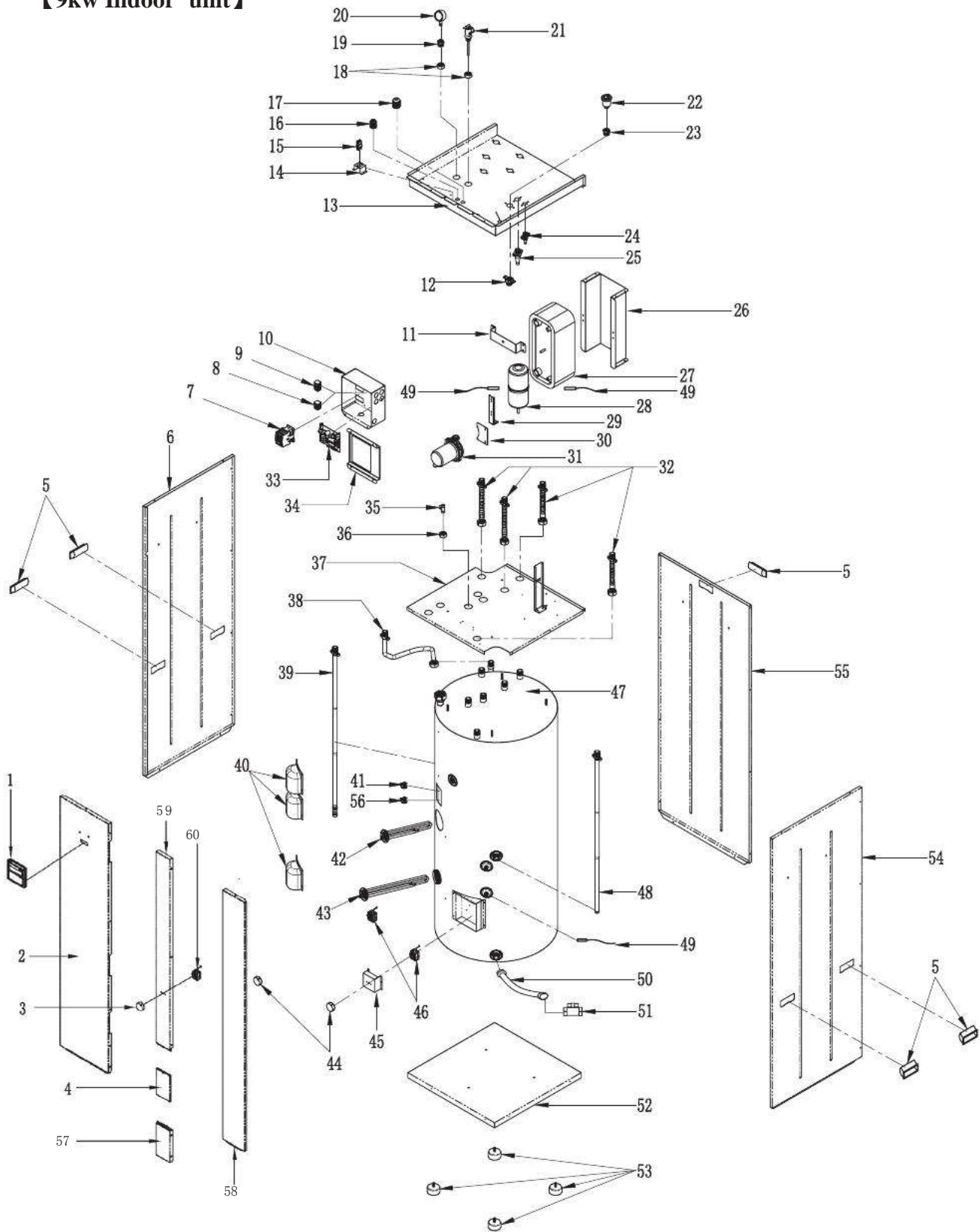

Before use

No.	Name	Quantity	No.	Name	Quantity
1	Wired controller	1	32	Stainless steel coil 1	4
2	Front panel 1	1	33	Controller	1
3	Thermostat knob	2	34	Bracket for electric box	1
4	Front panel 2b	1	35	T type three way valve	1
5	Handle	5	36	Copper nut	1
6	Left panel	1	37	Middle plate	1
7	AC contactor	1	38	Stainless steel coil 2	1
8	4 bit terminal block	1	39	Stainless steel coil 3	1
9	3 bit terminal block	1	40	Plastic cover	3
10	Electrical box	1	41	Overheating protector for 1.7KW electric heater	1
11	Bracket for plate heat exchanger 2	1	42	Electric heater	1
12	Connector adaptor 2	1	43	Electric heater	1
13	Top panel	1	44	Thermostat knob	2
14	Bracket of rubber base	1	45	Thermostat bracket	1
15	Rubber base	1	46	Thermostat	2
16	Cable gland Pg16	1	47	Water tank	1
17	Cable gland Pg21	2	48	Stainless steel coil 4	1
18	G1/2" female connector	2	49	Sensor	3
19	Connector adaptor 1	1	50	Stainless steel coil 5	1
20	Water pressure gauge	1	51	Ball Valves	1
21	T/P valve	1	52	Bottom plate	1
22	Automatic exhaust valve	1	53	Rubber feet	4
23	Connector adaptor 2	1	54	Right panel	1
24	G3/8" liquid valve	1	55	Back panel	1
25	G1/2" gas valve	1	56	6KW electric heater	1
26	Bracket for plate heat exchanger 1	1	57	Front panel 2c	1
27	Plate heat exchanger	1	58	Front panel 3	1
28	Refrigerant expansion tank	1	59	Front panel 2a	1
29	Water pump bracket 2	1	60	Thermostat	2
30	Water pump bracket 1	1			
31	Water pump	1			

Before use

【6KW Outdoor unit】

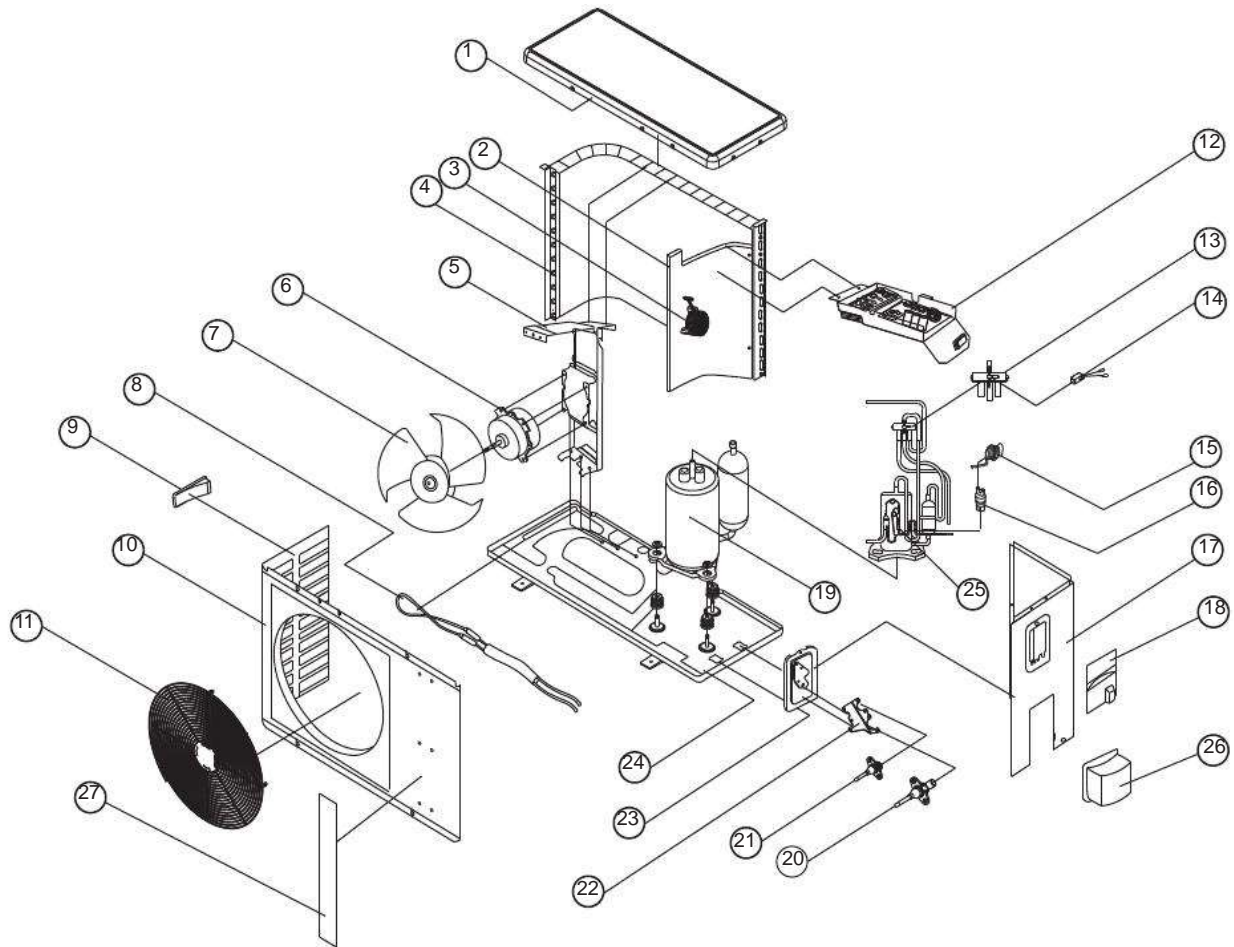

No.	Name	Quantity
1	Top panel	1
2	Bulkhead	1
3	PFC transducer	1
4	Condenser	1
5	Motor bracket	1
6	Outdoor motor	1
7	Outdoor fan	1
8	Condenser heater	1
9	Handle	1
10	Front panel	1
11	Fan guard	1
12	Controller	1
13	Four-way valve	1
14	Four-way valve coil	1

No.	Name	Quantity
15	Capillary	1
16	Filter	1
17	Right plate	1
18	Big handle	1
19	Compressor	1
20	1/2" gas valve	1
21	1/4" liquid valve	1
22	Quick connector plate	1
23	Valve plate	1
24	Bottom plate	1
25	One way valve	1
26	Valve cover	1
27	Decorative panel	1

Before use

【9KW Outdoor unit】

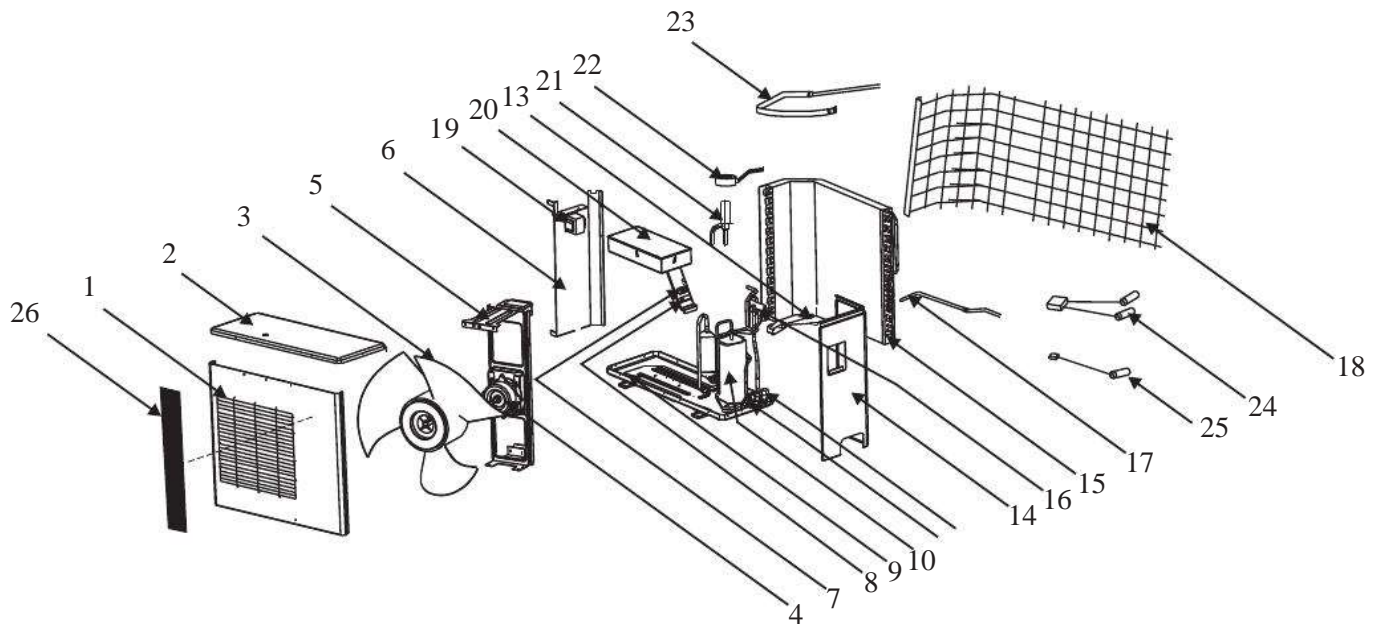

No.	Name	Quantity
1	Front panel	1
2	Top panel	1
3	Outdoor fan	1
4	Outdoor motor	1
5	Motor bracket	1
6	Bulkhead	1
7	Terminal block	1
8	Wire clip	1
9	Bottom plate	1
10	Compressor	1
11	3/8" liquid valve	1
12	1/2" gas valve	1
13	Four-way valve coil	1

No.	Name	Quantity
14	Right plate	1
15	Condenser	1
16	Four-way valve	1
17	Bottom plate heater	1
18	Coil guard	1
19	PFC transducer	1
20	Electric box	1
21	Electric expansion valve	1
22	EEV coil	1
23	Condenser heater	1
24	Sensor	2
25	Compressor discharge sensor	1
26	Decorative panel	1

Installation



The installation of the product should be handled by professional installer or under their instructions.

【Tools】

Most people already have the tools needed for installation: spirit level, pencil, crosshead screwdriver, drill 8mm. concrete drill bit, square, tape measure or ruler, tape width 65 mm, hole saw about 80mm (size may change), knife and two adjustable spanners or pliers (and possibly torque wrench).











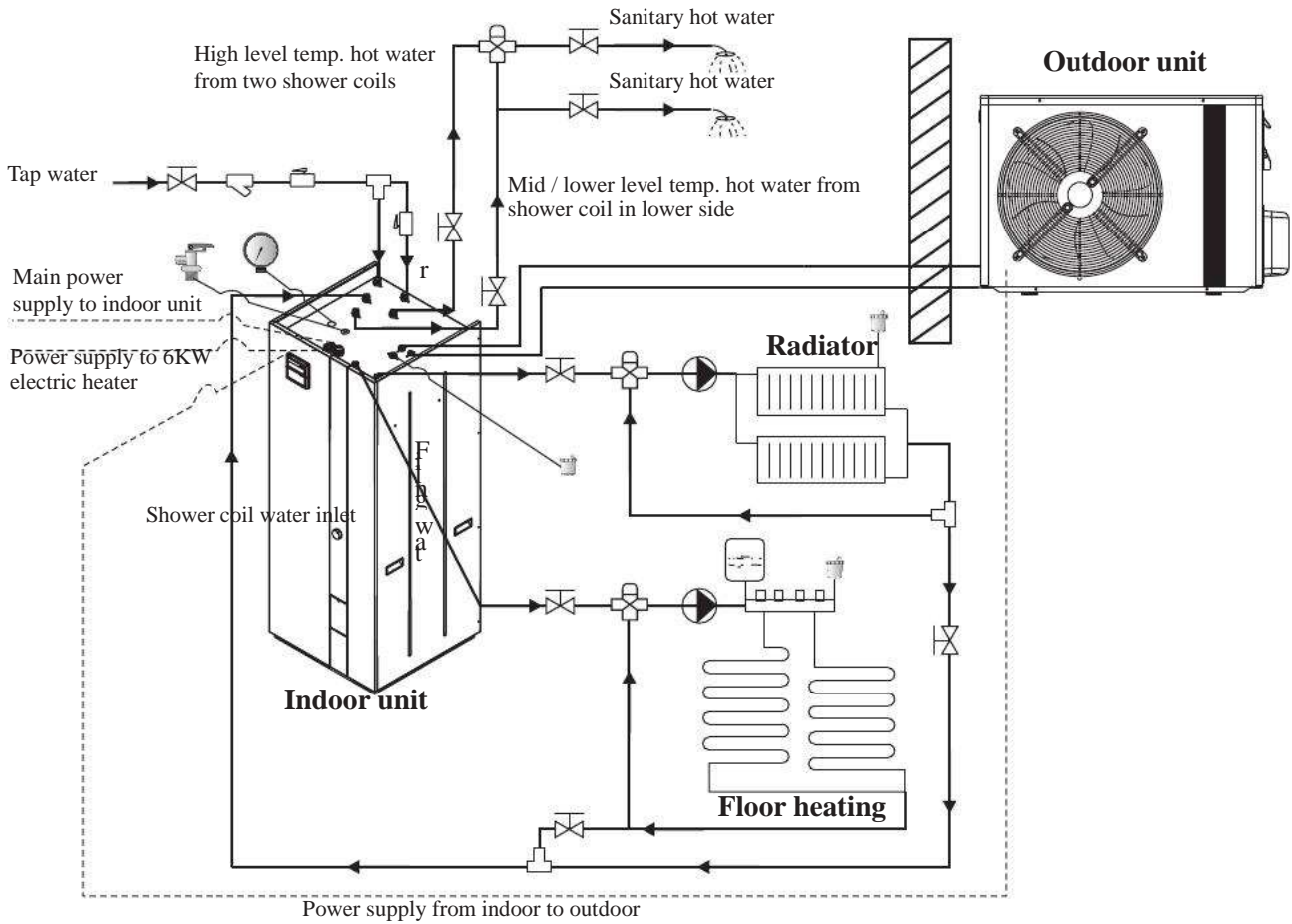

1. Installation methods

Indoor unit has connections on top for sanitary hot water, floor heating hot water and radiator heating hot water. With its inbuilt 1.7kW and 6kW electric heater, it ensures its heating capacity in cold days and guarantees enough high temperature sanitary hot water.

By using a mixture valve to mix high and medium temperature sanitary hot water together, it ensures the ideal temperature of sanitary hot water and increases the amount of sanitary hot water as well.

Installation



Symbol	Name
	Mixture valve
	Water pump
	Filter
	T/P valve
	One way valve
	Automatic air vent valve
	Water pressure gauge
	Shutoff valve
	Three-way valve

2. Installation of the indoor unit

【Installation notes】

- A. The indoor unit can be located in a room, corridor, balcony, garage or warehouse.
- B. Indoor unit should be placed on flat and solid ground.
- C. The unit is recommended to be put in a space close to water supply, and drainage.
- D. The outdoor and indoor unit should be placed close to each other, to save the copper tube as well as the energy.
- E. The indoor unit shall be placed in dry and well-ventilated environment.
- F. Indoor unit mustn't be installed in an environment where volatile, corrosive or flammable liquid or gas exists.
- G. During the movement, please be careful to keep the unit vertical. If the unit is tilted by 30° , it may fall down and cause damage to itself or the porter.
- H. Don't expose the operation panel under direct sunshine.
- I. Enough space should be left around the indoor unit for further maintenance.

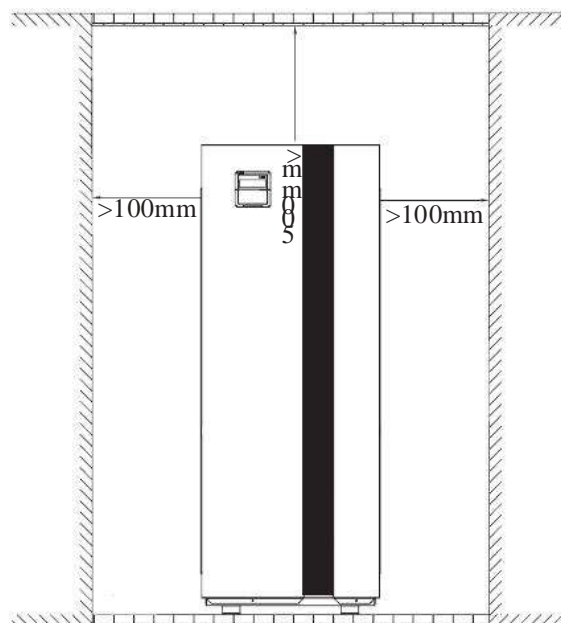

Installation

3. Installation of the outdoor unit

3.1 Installation notes

- A. The outdoor unit can be located in corridor, balcony, and roof or hanged on the wall.
- B. Please don't install outdoor unit close to bedroom or living room, because there is some noise when it's running.
- C. The outdoor unit shall be placed in dry and well-ventilated environment.
- D. Outdoor unit mustn't be installed in an environment where volatile, corrosive or flammable liquid or gas exists.
- E. Please cover a protecting roof over the outdoor unit, lest ice or snow blocks the air inlet. Shield the unit from direct sunshine, rain or snow, but never cover the unit which will cause the bad ventilation.
- F. Please ensure there is drainage system around the location, to drain the condensated water in defrosting mode.
- G. Please don't install the indoor and outdoor unit in damp locations, otherwise it may cause short-circuit or corrosion of some components. The unit should be free from corrosive and moisture surrounding. Otherwise the lifetime of the unit might be shortened.
- J. When installing the unit in harsh climatic conditions, sub-zero temperatures, snow, humid area, please raise the unit above the ground by about 20cm.
- I. When installing the unit, tilt it by 1cm/cm to left side of the unit (see from front), for better water drainage.
- J. Outdoor unit should be placed on flat and solid ground. When installing the outdoor unit, please ensure enough space around the outdoor unit, for better ventilation and maintenance. Please refer to the illustration below.

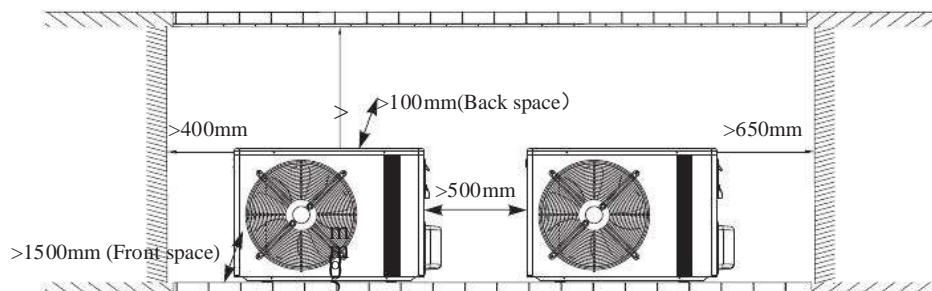

Installation

3.2 Installation



Please add rubber absorber under the outdoor unit, to reduce the vibration.

【A. On a concrete stand】

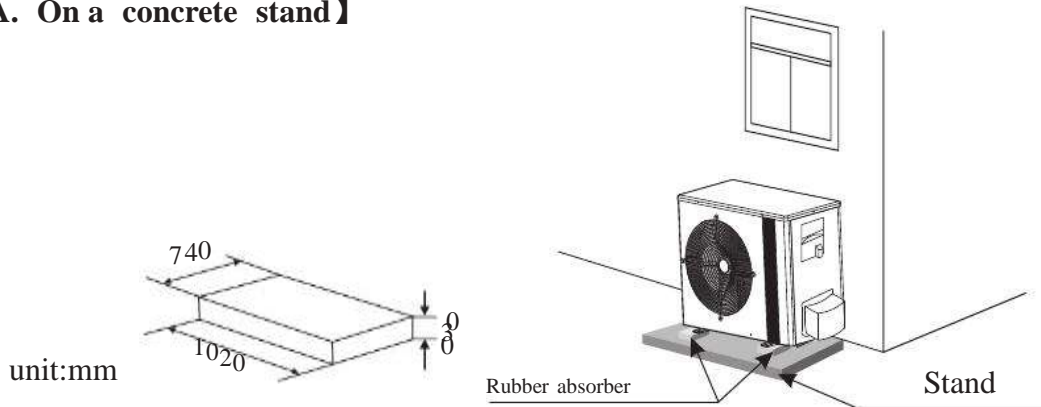

【B. On brackets on the wall】

1. Fix the bracket on the wall with expansion bolts.
2. Place the outdoor unit on the bracket. Rubber absorbers are recommended to reduce the noise of the outdoor unit.
3. Fix the unit to the bracket.

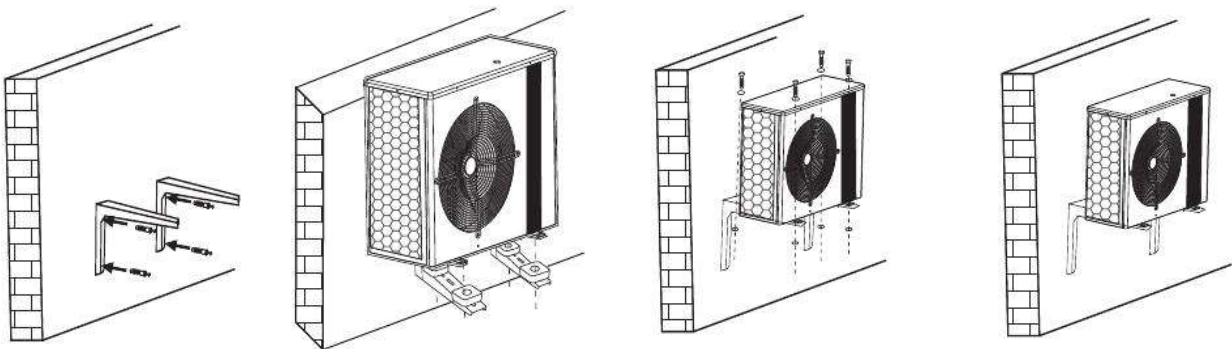

The refrigerant piping and signal cable between indoor and outdoor unit should go through the wall by using a wall sleeve. The hole should lean to outside a little bit (≥ 8 degrees), to prevent rain water or condensate water flowing back to the indoor.

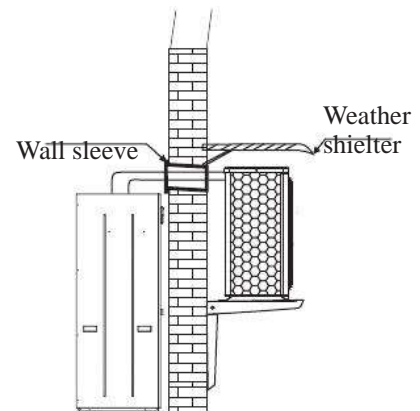

Installation

4. Wiring

【Precaution:】

1. The appliance shall be installed in accordance with national wiring regulations.
2. It is recommended to use a suitable circuit breaker for the heat pump and make sure the power supply to the unit corresponds to the specifications. Otherwise the unit might be damaged.
3. The power supply to the heat pump unit must be grounded.
4. Cable should be fixed tightly, to ensure it won't get loose.

4.1 Power cable between indoor and outdoor unit

For the installation of the power cable between indoor and outdoor unit, please refer to the followings:

Cable packed together with the piping kit.

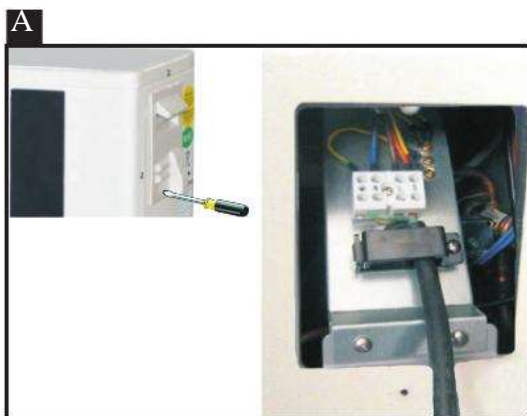
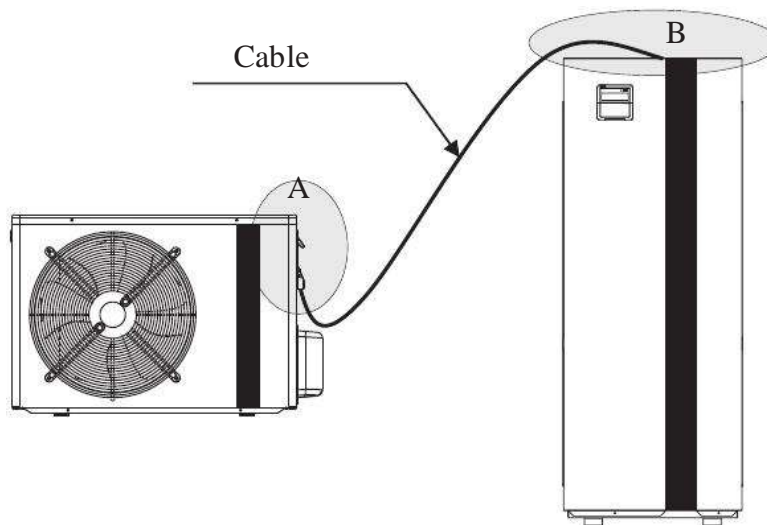

Take off small cover in outdoor unit, connect the power cable to the outdoor unit, according to the wiring diagram.

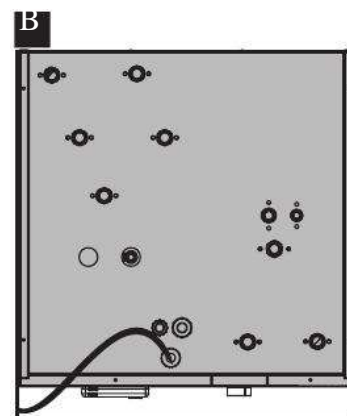

Connect the other end of the cable to the quick connector on the top of indoor unit.

Installation

Notice: When fixing the power cable with the wire clip, please be careful to clamp on the outer layer insulation, don't clamp on the wires inside, or it may cause damage on insulation layer of one-core wire.

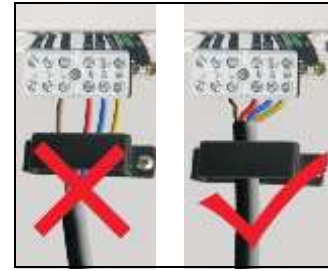

Attention:

When connecting the power cable between the outdoor unit and indoor unit, cables connected to the terminal block in indoor unit must match those in outdoor unit. For example, if the terminals and power cables are connected as  → yellow cable, L → red cable, N → blue cable, S → black cable in indoor unit, the connections in the outdoor unit should be in the same way.



Installation

4.2 Wiring of 6kW electric heater

1. The default wiring for 6kW heater is for 400V/50Hz/3Ph power supply. Here is how the heater is connected:

Please note: If the wire for this heater need to be changed, the substitute cable should be no smaller than 1.5mm.

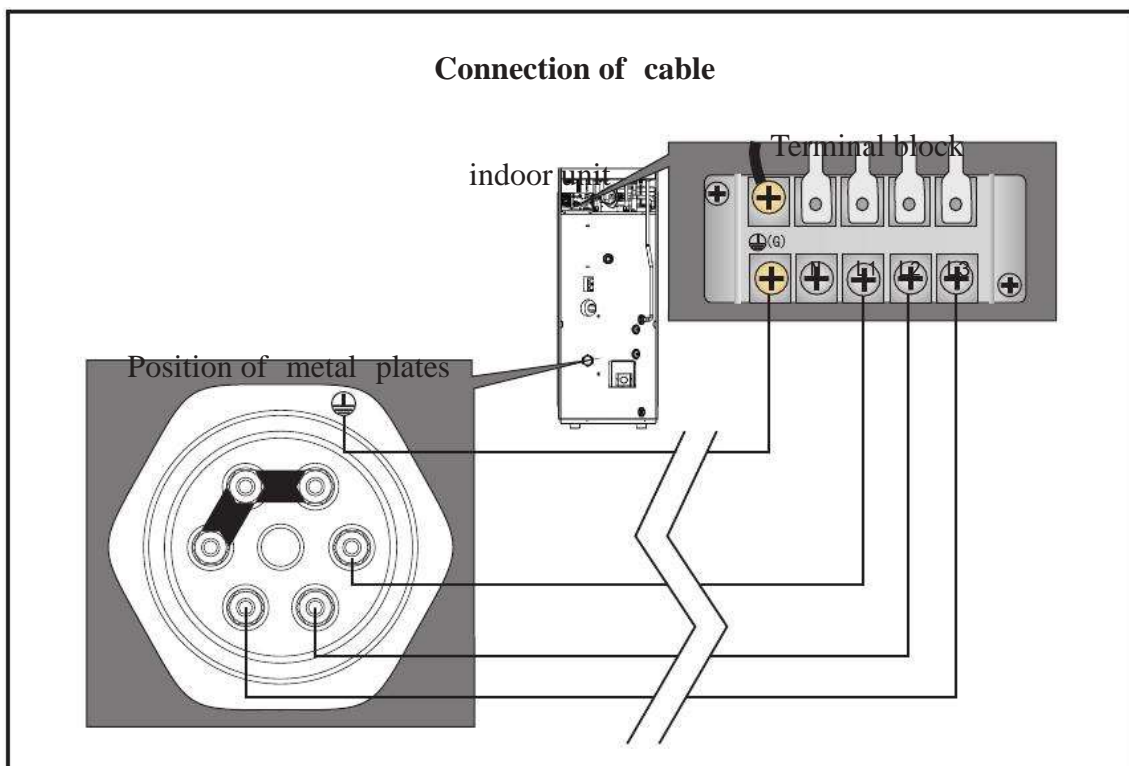
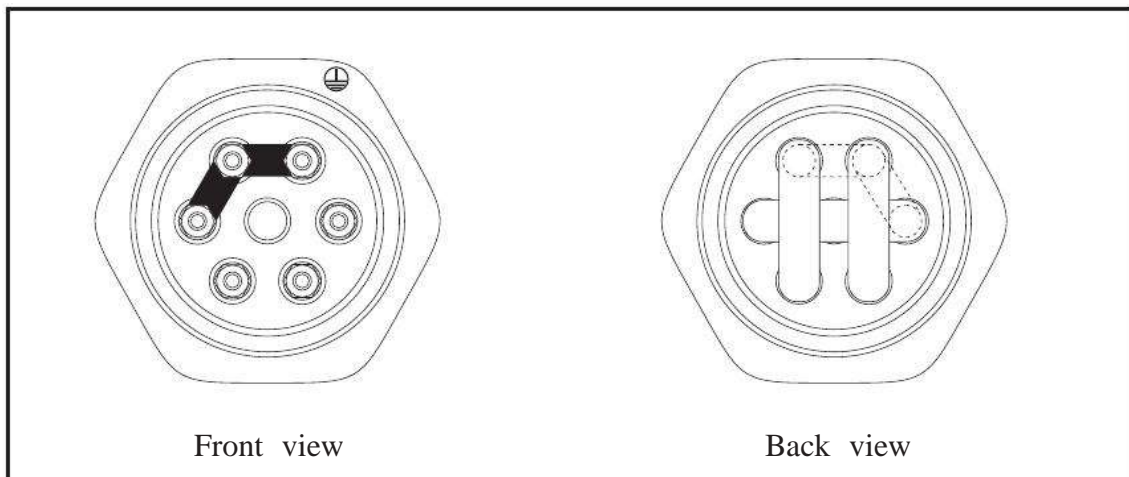

Installation

2. If this heater need to work with 230V/50Hz/3Ph power supply, please change the wiring as following:

as following:

2

Note: the cable size should not be smaller than 2.5mm under this application

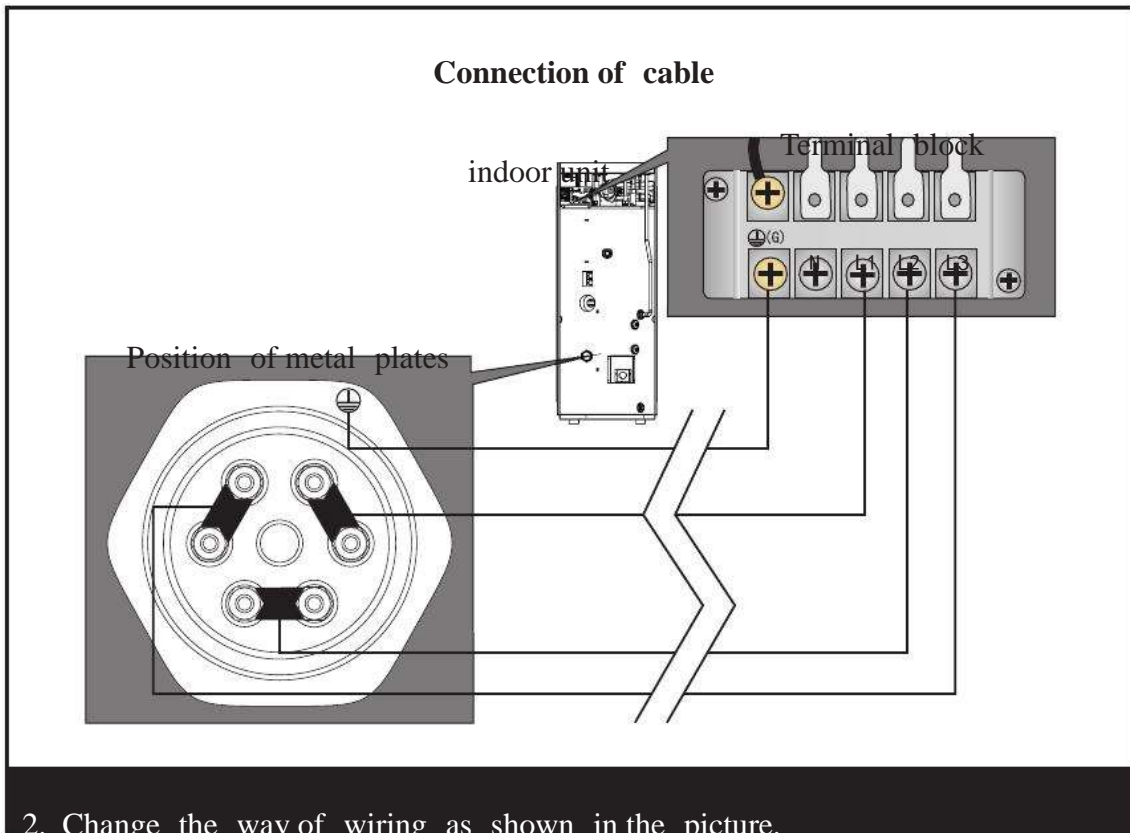
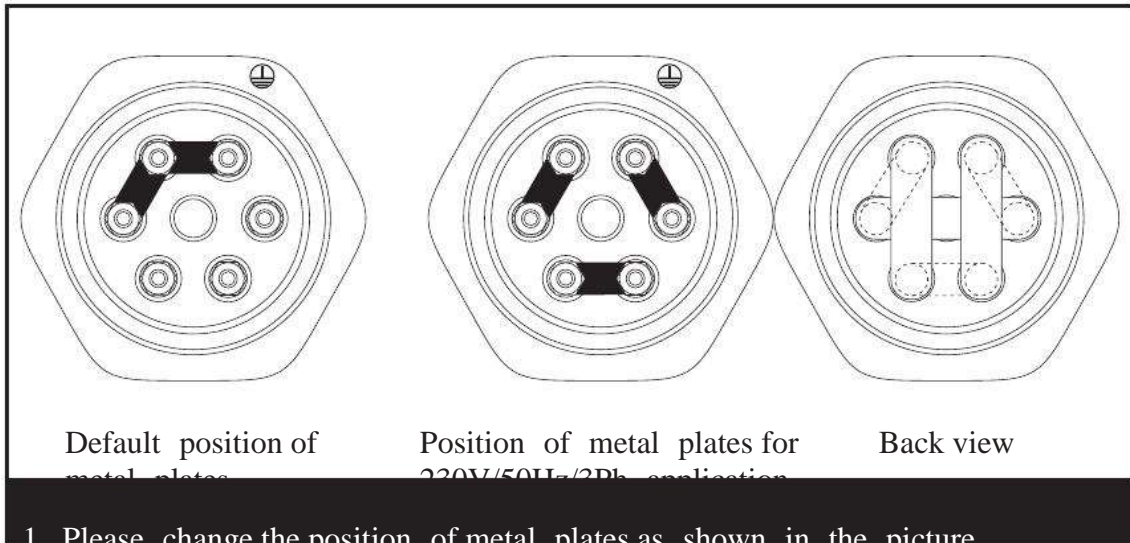

Installation

5. Refrigerant pipe connection

 Gas amount: The gas in the unit is enough for 5M long piping kits; If the piping is beyond 5M, please add 40g per extra meter. For example, if the piping is 10M long, please add $(10-5) \times 40 = 200\text{g}$ into the system. It's recommended that the gas piping shouldn't be longer than 12m.

Note: When vacuuming the system, please don't open the high/low valve spindles. Otherwise refrigerant leaks.

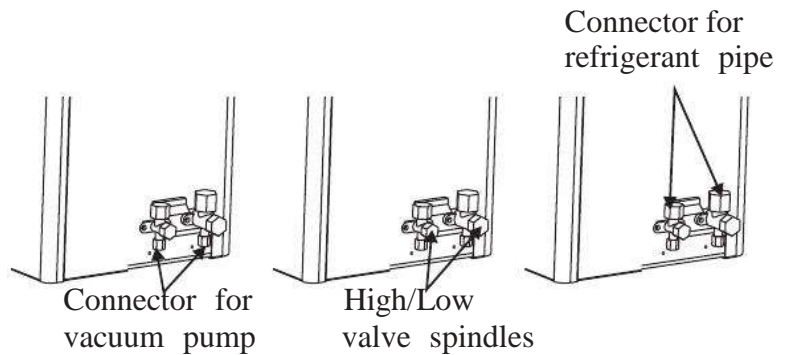

【Precaution:】

The refrigerant pipe transfers heat in the whole system. Incomplete vacuum or leakage of refrigeration system will lead to low performance, so please pay special attention to the following:

- A. Choose high quality refrigerant pipe, which conforms to the pressure requirements of R410A.
- B. Please well insulate the refrigerant pipe before connection.
- C. Check strictly the joints of refrigerant pipe, to avoid leakage.
- D. Try to avoid excessive bending of the refrigerant pipe, to ensure smooth circulation of refrigerant.
- E. Please dry the refrigerant pipe before connection, to avoid moisture in the pipe.
- F. If there is a wall between indoor and outdoor unit, please drill a hole on the wall, place a wall

sleeve in the hole and then run the refrigerant pipe through the wall sleeve.

- G. When insulating the refrigerant pipe, please insulate each pipe separately (refer to figure 1 below), don't insulate

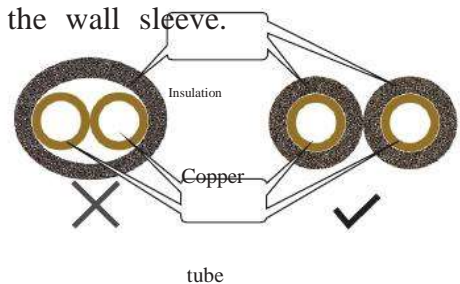

tube

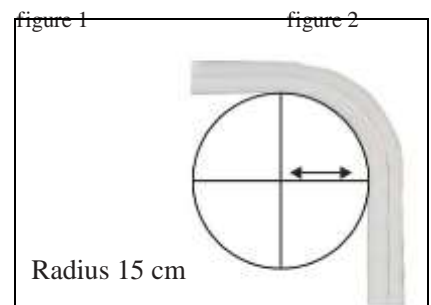

F. IMPORTANT:

The radius at pipe bends must not be less than 15 cm. Use a cardboard template to check this. Run the power cord along with the pipes. Create the bends gradually and carefully. Do not bend the pipe straight across, for example, to the edge of the hole in the wall.

Installation

【Installation:】



1. Connect the refrigerant piping to the indoor unit.



2. Connect the other ends of the refrigerant pipe to the outdoor unit.



3. Prepare a vacuum pump and a pressure gauge, connect one tube of the pressure gauge to the vacuum pump.



4. Connect the other tube of the pressure gauge to the outdoor unit.

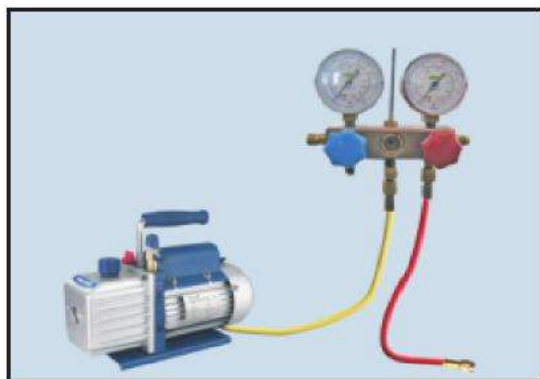

Attention: The liquid valve can't be opened until the vacuumizing has been totally finished.

5. Open pressure gauge, and start the vacuum pump to vacuum the unit for around 10 minutes. When the pressure gauge shows negative pressure, close the pressure gauge and stop vacuuming.

Installation

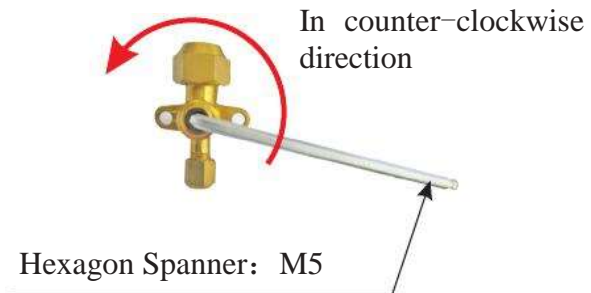
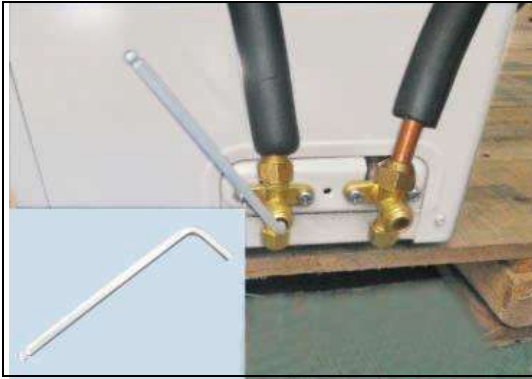

6. Take off the copper nut of the gas and liquid valves, open the valves with hexagon spanner as much as possible.



7. Check with leakage detector or soap water if there is any leakage. If not, then put back the copper nuts onto the valves.

6. Water pipe connection

After installing the unit, please connect the water inlet and outlet pipe according to the local regulations. Please carefully select and operate the water pipe.

After connection, the water piping should be pressure tested and cleaned before use.

【Water filling】

▲ One way valve:

One way valve must be installed to water filling connector, to avoid back-flow of water when water supply stops or water pressure not enough (one way valve is packed with the unit).

▲ Filter:

A filter (20 mesh/cm²) should be installed at the water inlet of water tank as well as that of indoor unit, to avoid sediments and guarantee water quality.

▲ Ball valve:

A ball valve is recommend for easy operation of drainage or filter cleaning.

Installation

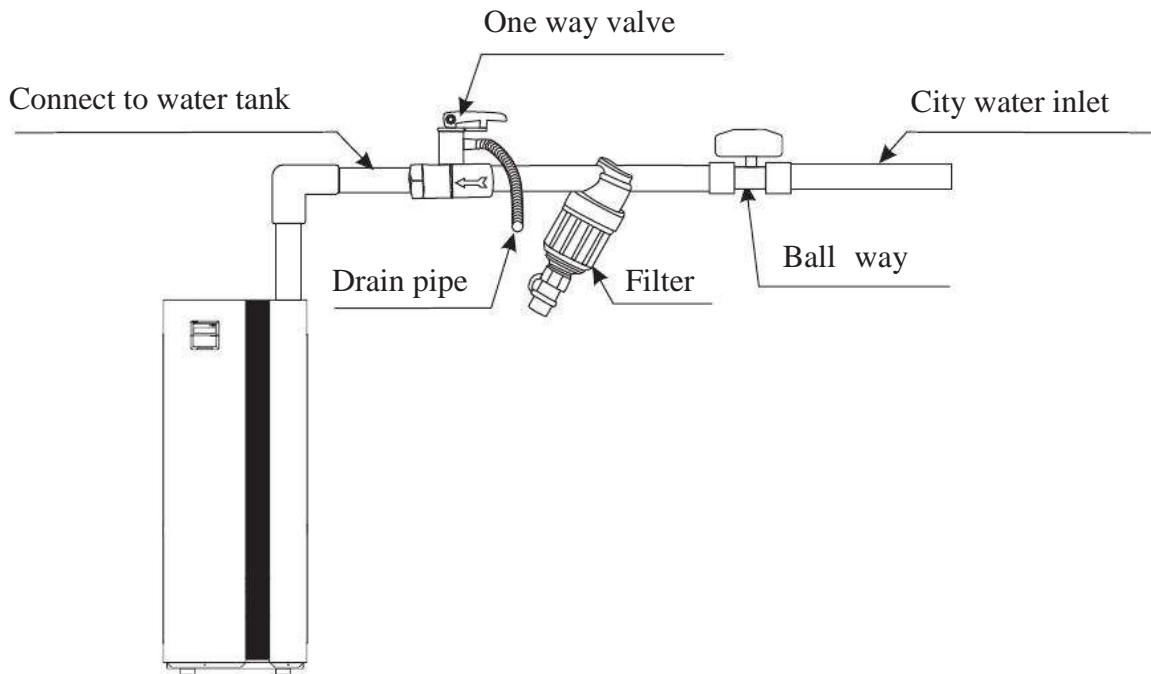

【Connect of drainage pipe】

When the tank needs to be drained, please do as per following instruction:

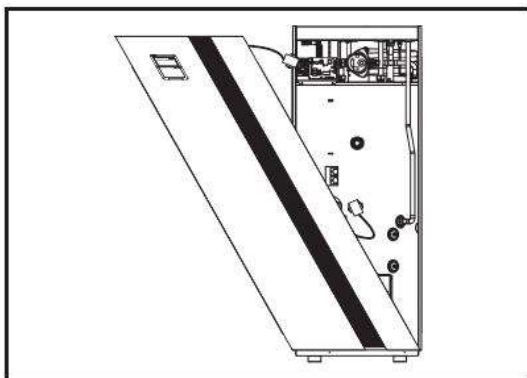

1. Take off the front panel (please watch the wires in between. Please disconnect all cables in between before the front panel fully opened).

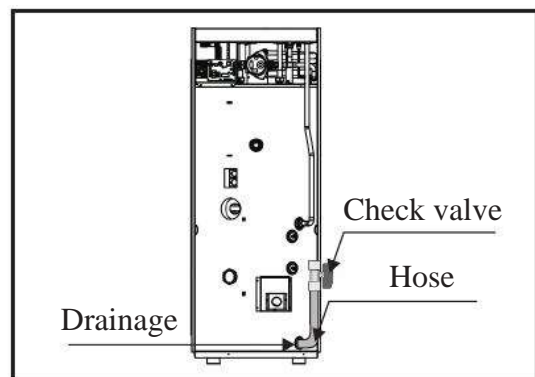

2. A hose and ball valve have already been connected to the tank. Please pull it out from the unit.

Installation

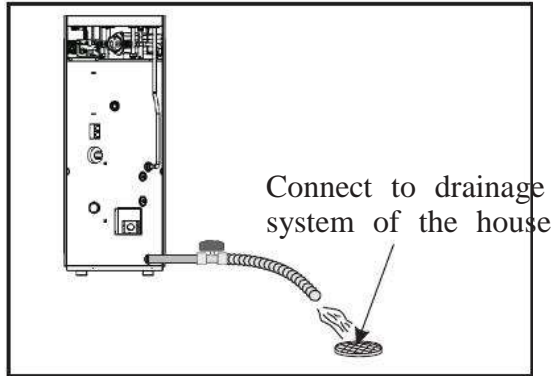

3. Drain the water to drainage system of the house, and open the ball valve to drain out all water inside the tank. Please extend the drainage pipe by connecting another water pipe, if the drainage hose is not long enough.

【Insulation】

All pipes running hot water should be well insulated. The insulation must be tied up tightly without gap (But please don't wrap up the check valve for future maintenance).



Please ensure enough water pressure to deliver the water to the required height. If the water pressure is not enough, please add water pump to increase the pumping head.

7. Installation of the kits in the accessories

7.1 T/P valve

In order to protect the water tank from too high pressure or temperature, please install the T/P valve

packed together with the unit, to the system:

1. Take out the T/P valve from accessories.
2. Apply sealant tape on threads of T/P valve according to the industry standards.
3. Find the connector on the top of tank according to the label, and install the valve onto it.
4. Connect the drainage pipe to the T/P valve as shown in the picture.

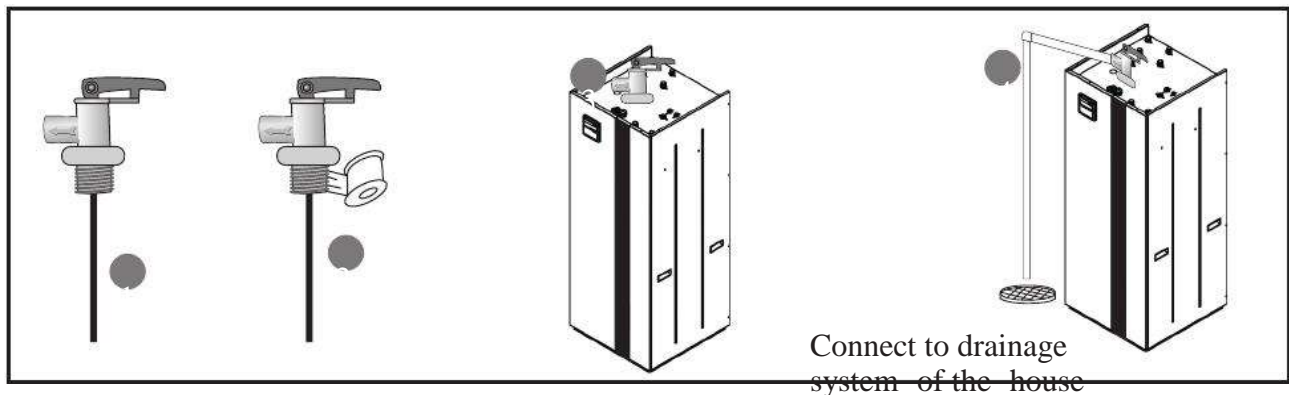

Installation

7.2 Automatic air vent valve

Automatic air vent valve is used to release air inside the water system. Please install it to the unit as followings:

1. Take automatic air vent valve and connector(3/4" to 1/2") out from accessories bag.
2. Connect the connector (3/4" to 1/2") to the valve, and tighten it with a wrench.
3. Apply the sealing tape to the thread of the connector clockwise at least four turns.
4. Connect it to the connector for automatic air-releasing on top of the unit.

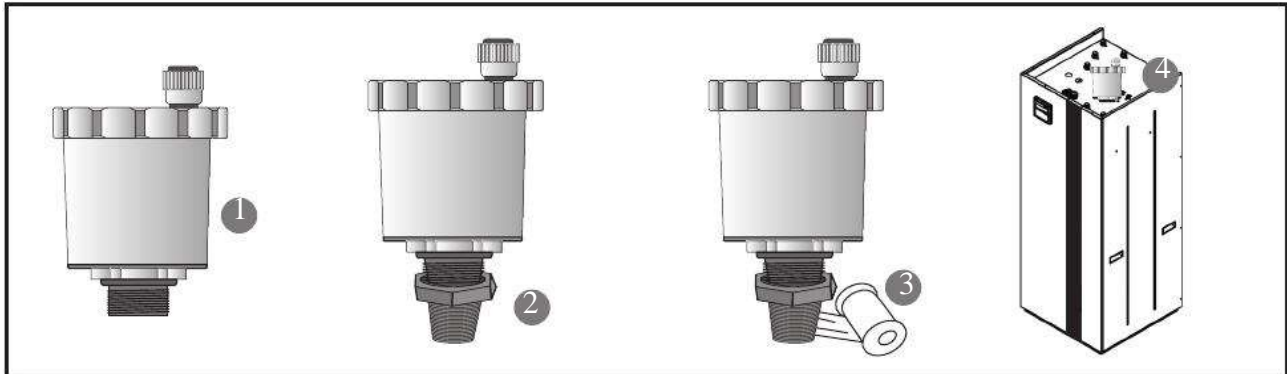

▲ After installing the automatic air vent valve into the right position, please open the small screw

cap on the top of the valve in order to ensure the air can be drained away.

▲ When the valve is blocked, close the small screw cap on the top of the valve and then remove

the valve and clean it. Then install the valve back to the top of water tank and open the small screw

cap again.

7.3 Water pressure gauge

For easy checking of water pressure, please connect the water pressure gauge to the unit:

1. Take out the manometer from accessories.
2. Apply the sealant tape on the threads of manometer according to the industry standards.
3. Find the connector on top of water tank according to the label, and install the manometer onto it.

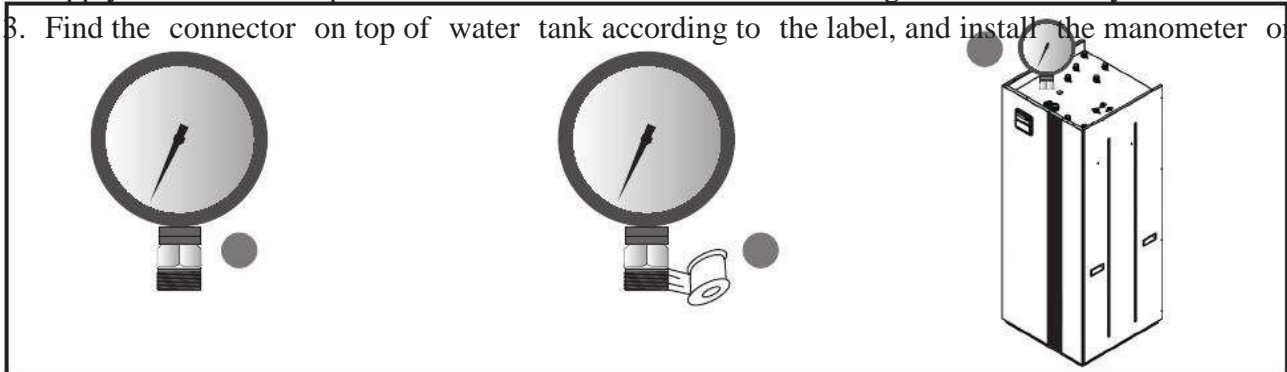

Installation

8. Water temperature sensor

The temperature sensor is placed in "temperature sensor 1" at factory(refers page 5), but if needed, it

can be moved to the position of "temperature sensor 2" (refers page 5), as follows:

1. Take off the cable fixture on plastic cover for "temperature sensor 1", and pull out the temperature sensor. Please install the cable fixture and its rubber o-ring back to the cap, for future demands.



2. Remove the plastic cover on the position of "temperature sensor 2" for installing the temperature sensor on the water tank, take off the plastic nut and remove the "O" shape rubber ring.



3. Pass the temperature sensor through the plastic nut and reinstall the "O" shape rubber ring.



4. After the temperature sensor passes through the plastic cover and completely insert into the temperature sensor 2 hole on the tank, please screw tightly the plastic nut.



Installation

9. Air purging of water system

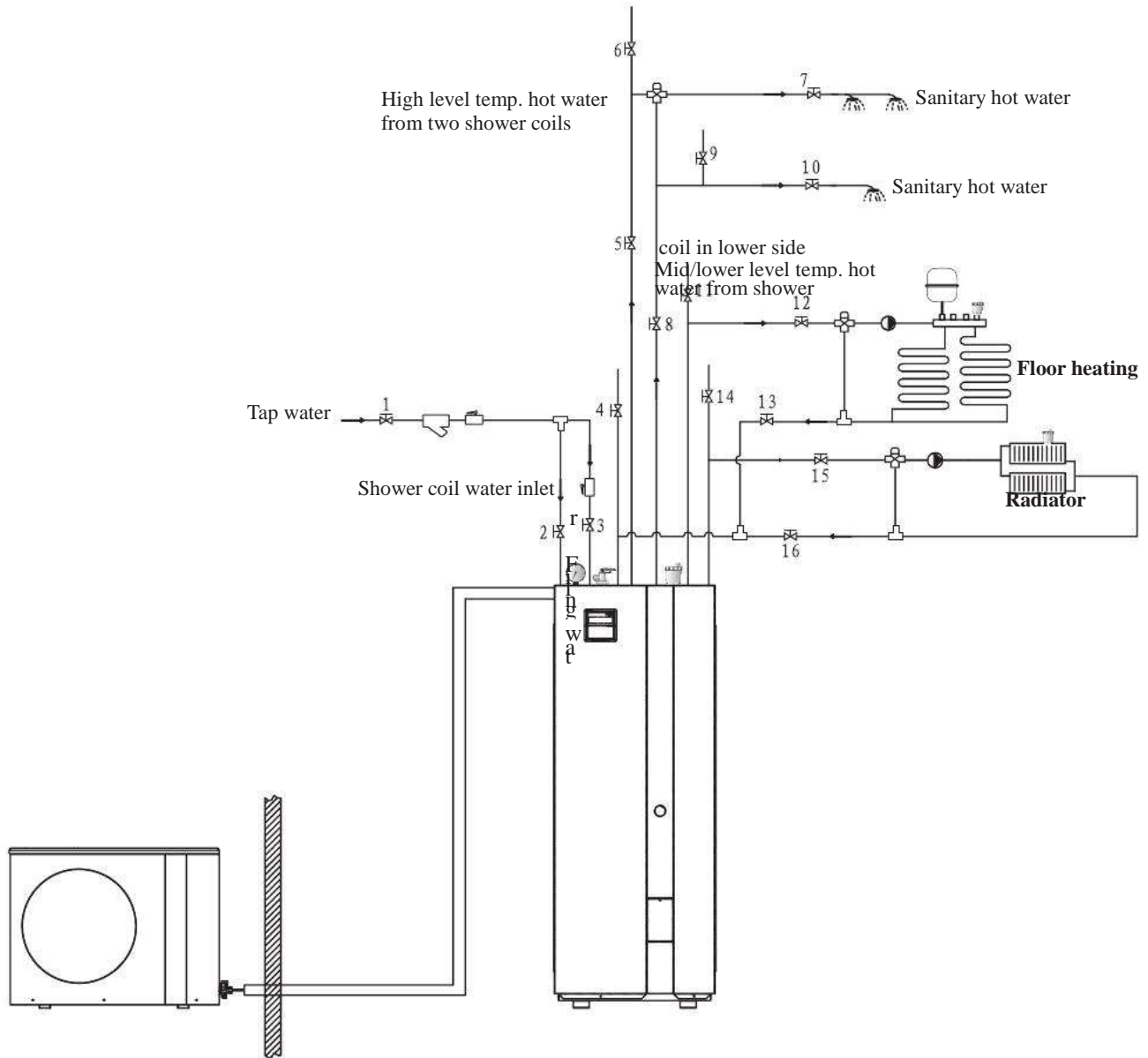

Symbol	Name
	Mixture valve
	Water pump
	Filter
	T/P valve
	One way valve
	Automatic air vent valve
	Water pressure gauge
	Shutoff valve
	Three-way valve

Installation

After finishing the installation, please refer the application illustration on page 32 and proceed with

the following steps to discharge the air in the system:

Evacuation of water tank

1. Close ball valve 2 and open ball valve 4,11,14.
2. Open ball valve 3 and 1, tap water enters into the water tank till water flows out from ball valve 4,11,14. Close ball valve 4,11,14.
3. The air vent valve and T/P valve discharge the air till water comes out from air vent valve and T/P valve without any air bubble.

Evacuation of shower coils in water tank

1. Close ball valve 7 and 10.
2. Open ball valve 2,5,6,8,9, some water enters into the shower coils in water tank till water flows out from ball valve 6 and 9. Close ball valve 6 and 9.
3. Open ball valve 7 and 10, till water comes out from two sanitary hot water outlets.

Evacuation of floor heating and radiator system

1. Open ball valve 1.
2. Open ball valve 12,13,15,16, to fill the water in the whole end system.
3. Use the air vent valve in the end system(floor heating and radiator system) to discharge the air till water comes out from the air vent valve.
4. Keep the ball valve 12,13,15,16 open. Close the air vent valve in the end system.

Note: During the whole process of air purging and after air purging is finished, keep the ball valve

1 open, and the ball valve of drainage inside the water tank should be closed.

10. Pre-Start up

10.1 Check before pre-start up

Before start-up, please check the following items:

- A. Check if the water pipes are connected well and if there is any leakage;
- B. Make sure the water supply valves are open and the water flows smoothly;
- C. Check if the power cable is connected well and properly grounded.
- D. Make sure the indoor and outdoor units have been installed in a flat and solid location.
- E. Check if the power supply corresponds with the specifications on the label.
- F. In cold area, please ensure the supply water flow is smooth without freezing.
- G. Check if the refrigerant pipe and water pipe are well insulated.



If everything above is OK, the unit can start up.
If any of them fails, please fix it.

10.2 Pre-start up









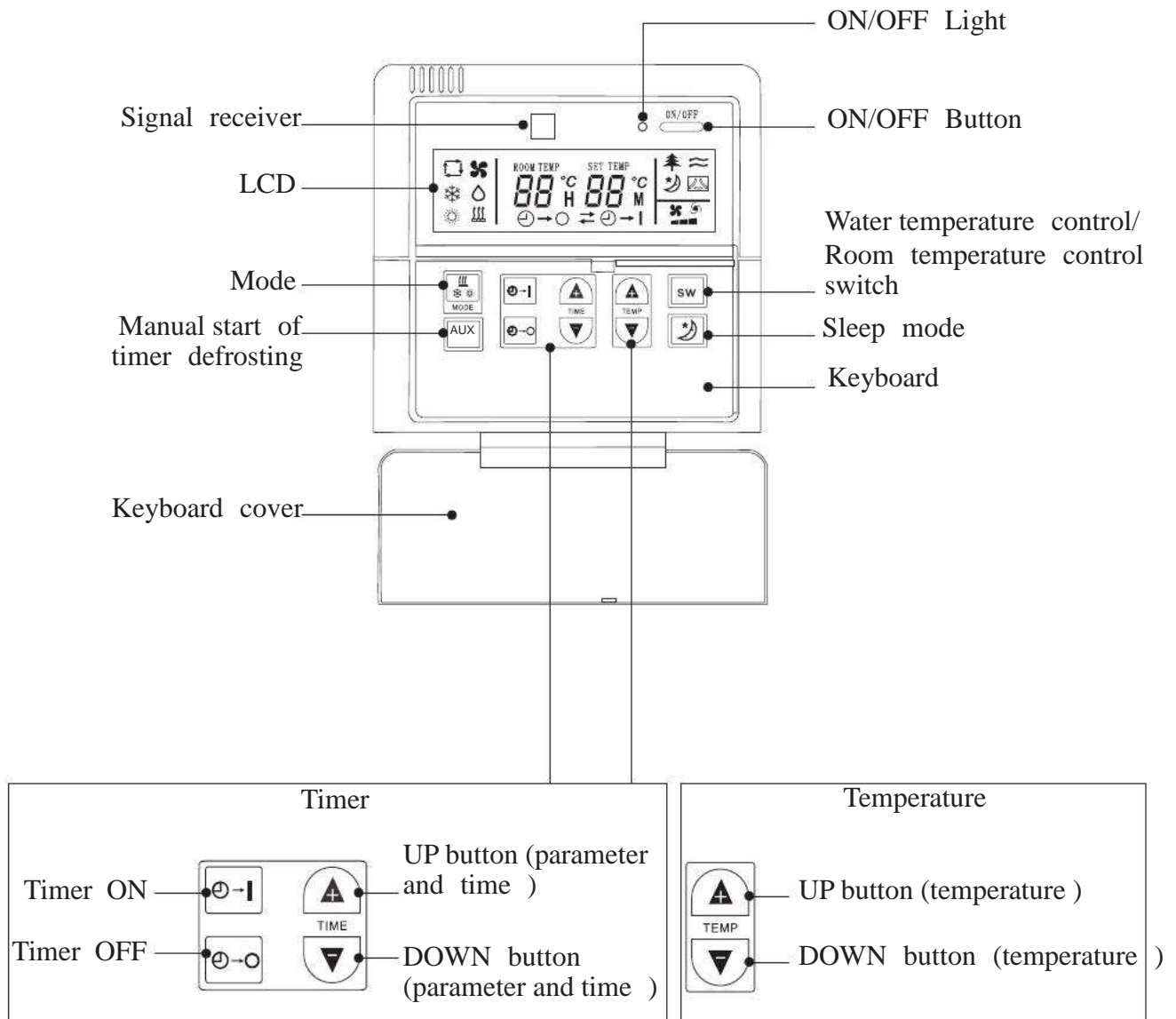







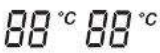

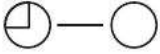
- A. When the installation of unit is completed, water system pipes are well connected and air purging is done, no leakage or other problems, the unit can be powered to start up.
- B. Turn on the unit, press the on-off button on the operation panel to start the unit. Please check carefully if there is any abnormal noise or vibration, or the display of wired controller is normal or not.
- C. After the unit is working properly for 10 minutes, without any problem, then the pre-start up is completed; If not, please refer to the Service and Maintenance chapter in this manual to solve the problems.
- D. Keep the unit running and check if the supply water temperature is the same as shown on the wired controller. If the water is not heated properly, please refer to “Trouble Shooting” to check the possible causes.



For this test-run, do not run "heating" or "hot water" mode when ambient temperature is over 32 °C, otherwise unit may go into protection mode easily.

1. Introduction of wired controller



LCD Display	Indication	Notes
	Heating mode	 is always ON in heating mode  flickers when the unit is defrosting in heating mode
	Hot water mode	 is always ON in hot water mode  flickers when the unit is defrosting in hot water mode
ROOM TEMP	Room temp. value	When adjusting temp. the pattern flickers
SET TEMP	Set temp. value	When adjusting temp. the pattern flickers
	Temperature	Air temp. display range: 0-75°C Water temp. display range: 0-99°C
	Timer	Shown on display only when timer function is activated.
	Timer OFF	
	Timer ON	
	Sleep mode	 is always ON in sleep mode
	Timer defrosting	When  is shown, unit works in timer defrosting mode compulsively.
	Compressor speed	Low speed :  Medium speed :  High speed : 

2. Operation on wired controller

ⓘ Standby

When unit is powered on, unit is in standby mode.



Use

2 ON/OFF

Press ON/OFF button to turn ON the , the unit will run in its last working mode.. Press ON/OFF again to turn off the unit. The unit will recover its last working settings automatically after power failure.



Note: After power failure, unit will recover its last working condition, but unit will relock its last timer setting, if timer function is activated.

3 Mode selection







After turning on the unit, press  to choose the operation mode. It comes in the sequence:



Heating mode is recommended if energy saving is needed.

Hot water mode is recommended if you need desired hot water urgently. Because in this mode, unit will work on its highest allowable speed to achieve its set temperature ASAP.

4 Temperature setting:

When unit is working, press  or  to increase or decrease temperature setting. By pressing  or  once, set temperature increased or decreased by 1°C. When keeping on pressing  or , set temperature will be increased or decreased in bigger step.

When temperature setting is in processing, "SET TEMP" symbol blinks. No operation in 5 seconds, temperature setting will be saved and exit automatically.



Temperature set range for heating mode:
25~52°C under water temperature control
16~31°C under room temperature control



Temperature set range for hot water mode:
25~52°C

Use

Logic defrosting and Timer Defrosting

When the unit works in heating or hot water mode, press AUX for 10 seconds, the unit can change from logic defrosting mode(default setting) to Timer defrosting mode.  shows. The unit works in Timer defrosting mode. In this mode, the unit will defrost at a fixed interval time on the condition that the unit needs to defrost.



Press AUX for 10 seconds again, the unit change from Timer defrosting mode to logic defrosting mode.  is not shown and unit works in logic defrosting mode. In this mode, the unit can automatically and intelligently adjust the defrosting interval time between each defrosting according to its previous defrosting process.

For dip switch JP4 on the outdoor PCB, when JP4=OFF, unit works in a fixed defrosting interval time (timer defrosting);

ON

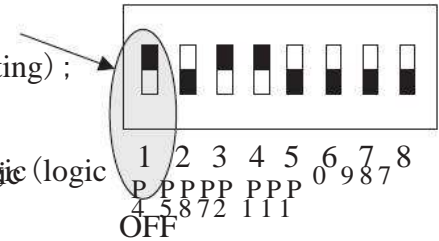

When JP4=ON, the unit works in self-defining defrosting logic (logic defrosting). (JP4=ON).

Water temperature control/Room temperature control switch



Please mind that when the unit works in room temperature control mode, it may not supply sanitary hot water with high enough temperature.

When the unit is working in heating or hot water mode, press "SW" to switch water temperature and room temperature control. When "ROOM TEMP" shows, room temperature can be set as target. When "ROOM TEMP" is not shown, water temperature can be set as target.

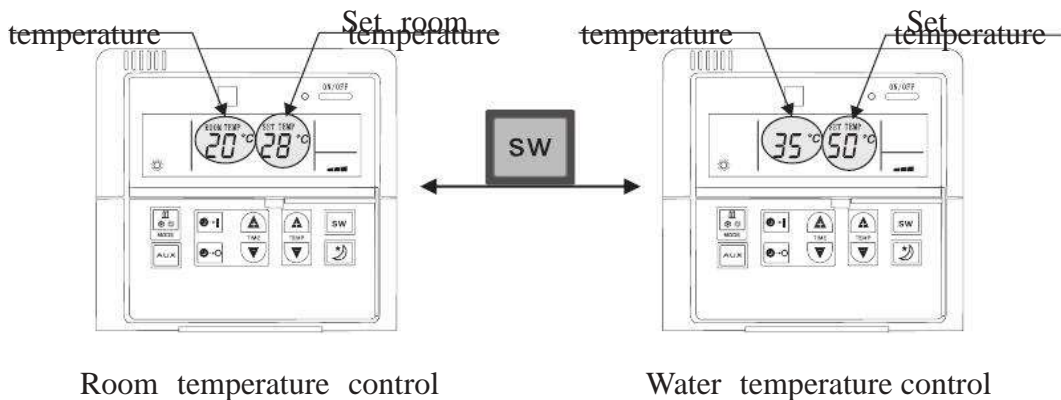

Use

⌚ Sleep mode

Sleep mode is available only when the unit is working with room temperature control in heating mode.

When the unit works in heating mode, and set room temperature control, press "☾" button once to activate sleep function, "☾" displays. Press "☾" button again, sleep mode exits and "☾" disappears. The working program of sleep mode is as follows:



The set room temp.

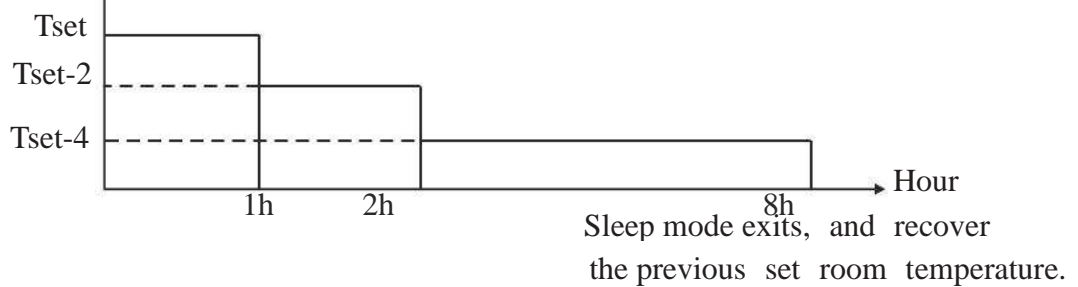

In heating mode, one hour after Sleep mode starts, temperature will become 2°C lower than temperature setting. After running for another 1 hour, temp. decreases by 2°C further. The unit will run for 6 hours at this temperature and exit from this mode. The unit automatically switch to the previous set room temperature before Sleep mode.

⌚ Timer ON/OFF



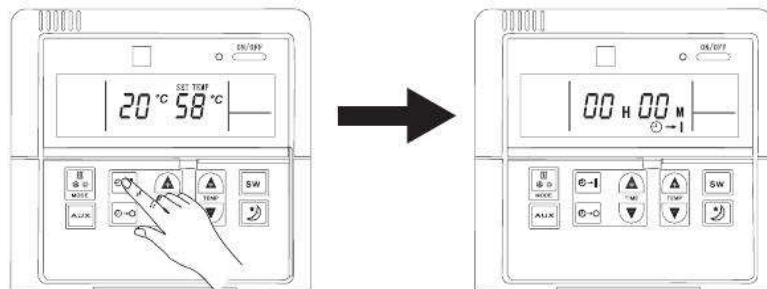

Timer ON/OFF of the unit can be set when unit is standby or working:

【Timer ON】





1. Press "E-1" to activate timer ON setting with "E-1" shown on the display.



2. Set Timer ON in hour and minute:

Timer setting in hour: Keep pressing  " to increase hour. Time setting is increased by 1 hour at each second when you keep pressing  ". Keep pressing  " to decrease hour. Timer setting is decreased by 1 hour at each second when you keep pressing  ". The setting range for hour is 0-23.

Timer setting in minute: Press  " once to increase minute. Time setting is increased by

1 minute at each time you press  ". Press   once to decrease minute. Timer setting is decreased by 1 minute at each time you press  ". The setting range for minute is 0-59.

Timer setting in hour

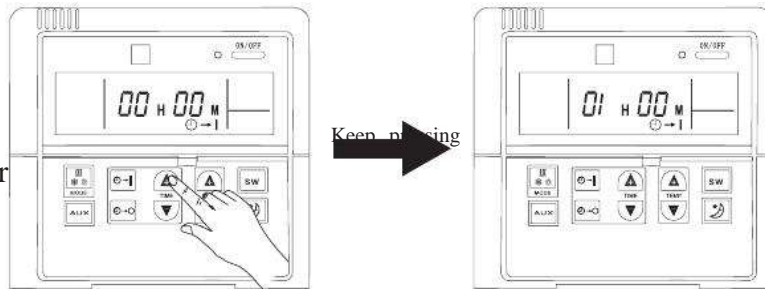

Timer setting in minute

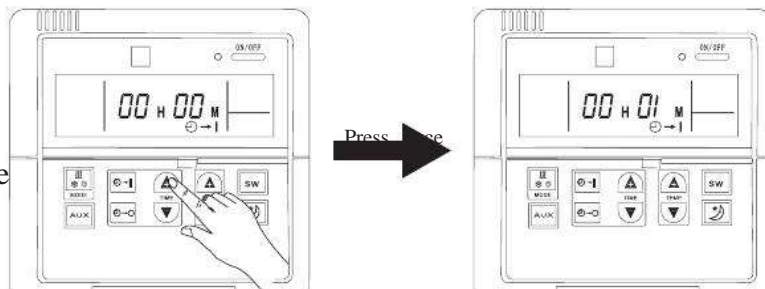

3. The Timer ON setting will be saved automatically after there is no operation for 5 seconds. Once Timer ON is set, timing starts. When the set time is up, unit turns on and Timer is cleared.

4. When unit is on standby, quickly pressing  two times, to check the setting for timer ON.

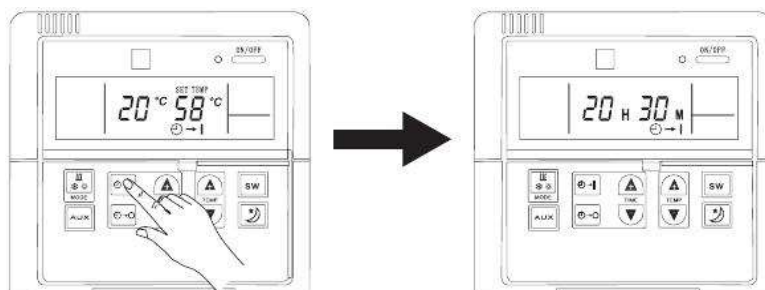





Use

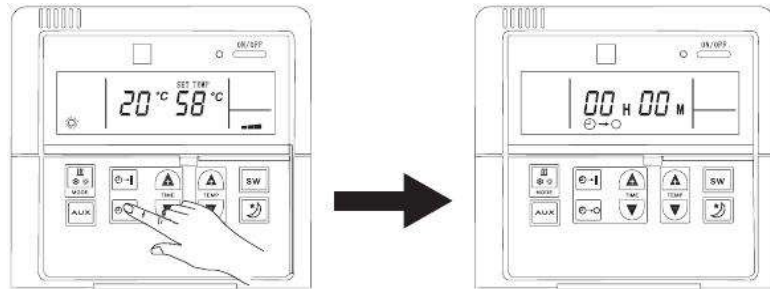



【Timer OFF】

1. Press  to activate timer OFF setting with  shown on the display.



2. Set Timer OFF in hour and minute:

Timer setting in hour: Keep pressing "  " to increase hour. Time setting is increased by 1 hour at each second when you keep pressing  ". Keep pressing "  " to decrease hour. Timer setting is decreased by 1 hour at each second when you keep pressing "  ". The setting range for hour is 0-23.

Timer setting in minute: Press "  " once to increase minute. Time setting is increased by 1 minute at each time you press "  ". Press "  " once to decrease minute. Timer setting is decreased by 1 minute at each time you press "  ". The setting range for minute is 0-59.

Timer setting in hour

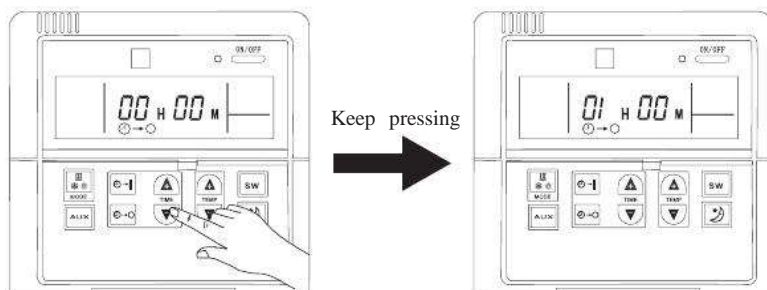

Timer setting in minute

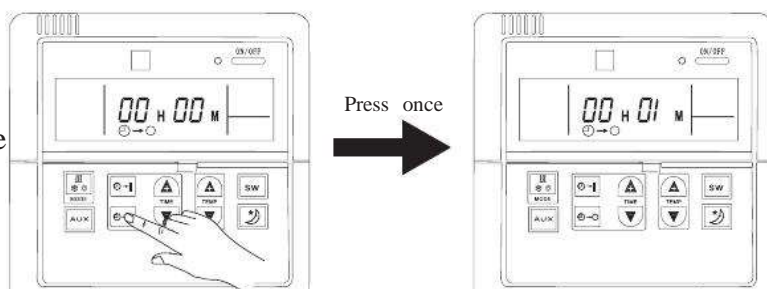

Use

- The Timer OFF setting will be saved automatically after there is no operation for 5 seconds. Once Timer OFF is set, before the time is up, the unit keeps on working normally. When the set time is up, unit stops working immediately regardless of the ambient temperature.
- When unit is working in heating mode or hot water mode, quickly pressing  two times, to check the setting for timer OFF.

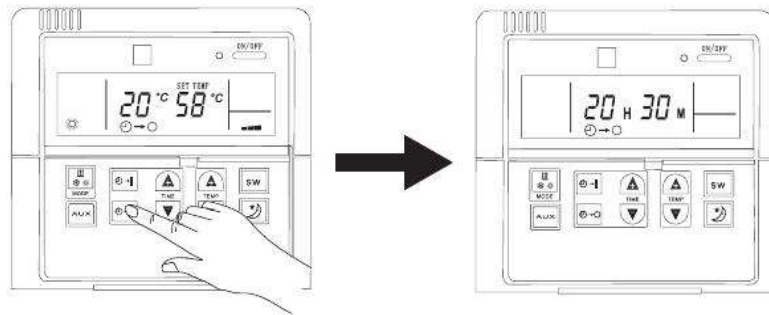

9 Antifreeze protection

First level



When the unit is on standby and ambient temperature $\leq 5^{\circ}\text{C}$, water pump starts, the wired controller shows code "P1".

When the unit is on standby and ambient temperature $> 5^{\circ}\text{C}$, water pump stops, the code "P1" disappears.

Second level



When the unit is on standby and ambient temperature $\leq 5^{\circ}\text{C}$ and water outlet temperature $< 3^{\circ}\text{C}$, the unit starts heating, the wired controller shows code "P2".

When the unit is on standby and ambient temperature $> 2^{\circ}\text{C}$ or water outlet temperature $> 8^{\circ}\text{C}$, the unit stops heating, the code "P2" disappears.



This protection is only valid when the water temperature is control object.

3. Error code

Item	Error Code	Causes	Ways to check and remedies
Wired Controller	E0	1.Wire connection between wired controller and PCB open or short-circuited. 2.Wired controller failure.	1.Check whether the wire connection gets loose.Fasten it. 2.Change it.
	E1	1.Indoor room temp. sensor in the wired controller open or short-circuited. 2.Indoor room temp. sensor resistance drifting. 3.Temperature sensors not well connected to the wired controller.	1.Measure with a multimeter at 20K to check whether it is short-circuited or open. If yes, change it.. 2.Measure with a multimeter at 50K to check the sensor resistance. Take ambient temp. into consideration. If it is drifting, change it. 3.Check whether the sensor connection gets loose. Fasten it.
System	F1	Communication failure	1.Check whether port "S" of indoor and outdoor unit gets loose. Fasten it. 2.Change the indoor PCB. 3.Change the outdoor PCB.
	F2	1. Indoor water inlet Temp sensor failure.	1.Check whether the sensor connection gets loose. Fasten it. 2.Wire connection between wired controller and indoor PCB open or short-circuited. 3.Indoor water inlet Temp sensor resistance drifting.
		2. Indoor water outlet Temp sensor failure.	1.Check whether the sensor connection gets loose. Fasten it. 2.Wire connection between wired controller and indoor PCB open or short-circuited. 3.Indoor water outlet Temp sensor resistance drifting.
		3. Indoor Coil Temp sensor failure.	1.Check whether the sensor connection gets loose. Fasten it. 2.Wire connection between wired controller and indoor PCB open or short-circuited. 3.Temp sensor resistance drifting, temp. sensor resistance drifting.
	F3	Current or Voltage detector failure	Change outdoor PCB
	F4	Compressor drive failure、IPM failure、IPM protection (overload)、drive protection	1.Check whether PFC transducer gets loose. Fasten it. 2.Change PFC transducer. 3.Change outdoor PCB.
	F5	Indoor EEPROM failure	1.Check whether EEPROM gets loose. Fasten it. 2.Change indoor EEPROM.
	F6	Too high indoor coil Temp in heating	1.Check the water flow of the unit. 2. Too high ambient and water Temp. Reduce the set water Temp.
		Too high outdoor pipe Temp in cooling	1.Check the water flow of the unit. 2.Too low ambient and water Temp. Increase the set water Temp.
		Over-current protection	1.Check the water flow of the unit. 2.Too high (low) ambient, and too high(low) set water Temp. Decrease or increase the set water Temp.
F7	Too high or too low voltage	1.Check the voltage of the power supply. 2.Change the outdoor PCB.	

Item	Error Code	Causes	Ways to check and remedies
System	F8*	Pressure switch failure	1.Check the pressure of the system. 2.Change the pressure switch.
	F9	Outdoor EEPROM failure	1.Check whether EEPROM gets loose. Fasten it. 2.Change outdoor EEPROM.
	Fb	Outdoor ambient temp. sensor failure	1.Check whether the sensor connection gets loose. Fasten it.
		Outdoor pipe temp. sensor failure	2.Wire connection between wired controller and indoor PCB open or short-circuited.
		Compressor discharge temp. sensor failure	3.Temp sensor resistance drifting.
	Fc*	System protection caused by too high (low) pressure	1.Measure the high (low) pressure switch with a multimeter to check whether it is short-circuited or open. If yes, change it.. 2.Check the water flow of the unit.
	Fd	System protection caused by the ambient Temp.	1.Check the ambient Temp sensor. 2.Check whether the ambient Temp is too high(low) for working (Ambient lower than -1 or higher than 65 in cooling, lower than -25 or higher than 45 in heating).
	Fe	Reserved error code	
FF	Indoor water Pump or flow switch failure.	1.Check the flow rate of the water pump. 2.Check the connection of the flow switch. Check if there is enough water flow in the system, the flow switch is closed or not. If not, change the flow switch.	

*Difference between F8 and Fc:

System Pressure Protection

During compressor's operation, when system pressure rises too high and pressure switch turns off, (in system's normal operation, pressure switch keeps on), the controller will lower compressor's running speed by 1Hz/s until pressure switch reconnects. Meanwhile, it records the compressor's current running speed, and takes the value one level lower as the maximum speed. This limit will be released automatically after compressor keeps on running for 2 hours. However, if during this process, similar pressure protection happens again, the controller will records the new running frequency and takes 1 level lower than this new frequency as the maximum speed. And it will release this protection in 2 hours after this new protection happens. If compressor is off, but pressure switch is disconnected for 5 seconds, the controller will judge it as "Pressure Switch Failure" and relevant error code will be shown in wired controller.

For check whether the system have this pressure switch failure or protection is due to hardware failure, we can do like this:

- 1.Turn the unit off, and cut the power. Leave the unit without power for 10 minutes.
- 2.Power up the unit.
- 3.If F8 comes right after the unit is on, then it is the pressure switch itself, or the cable loosened that causes F8 failure.

4.If not, then the refrigerant system is working abnormal, which causes this high pressure protection.

All followings may cause abnormal high pressure in the unit:

- ① Water flow too small
- ② Water filter blocked
- ③ Too much refrigerant
- ④ Water Temp. too high
- ⑤ Piping kit sharply bended
- ⑥ EEV failure

4. Electric heating

This unit has included two electric heaters inside. Two electric heaters are used to keep the water temperature when heat pump capacity is not enough or heat pump fails to work, as well as heat the water up more rapidly when water temperature is low.

4.1 1.7KW electric heater

1. 1.7kW electric heater is manually control only. It is not connected with controller of heat pump.
2. Power supply is 230V/50Hz/1Ph, and temperature setting range is 30~75°C.
3. This heater is mainly used to get high temperature sanitary hot water or get hot water faster.
4. If heat pump fails to work, this heater can still work.

Operation knob for 1.7kW heater is on front panel, for easy access. Please refers to following picture.

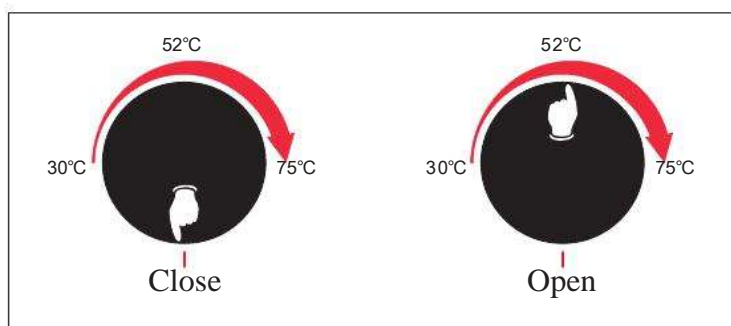

4.2 6KW electric heater

1. 6kW heater is connected to indoor PCB, and under the control of the unit.
2. Power supply is 400V/50Hz/3Ph, and set temperature range is 30~75°C. If there is only 230V/50Hz/3Ph power supply, please refer to chapter "Different wiring of 6KW electric heater".
3. On top of the indoor unit, there is a power cable for this heater. Please connect it to a breaker which is enough for 6kW.
4. 6kW is mainly used as an auxiliary heating for house heating.
5. When heat pump fails to work, please set the thermostat of this heater to a correct setting, so it can work as a back-up heater.
6. Please pay special attention to the temperature setting of this heater. If the set value of this heater is higher than heat pump temperature setting, it may happen that main heat would be generated by electric heater, instead of by heat pump.

Please do as follows to get access to thermostat for 6kW electric heater:

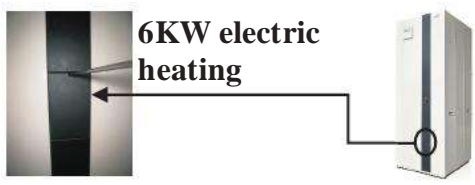
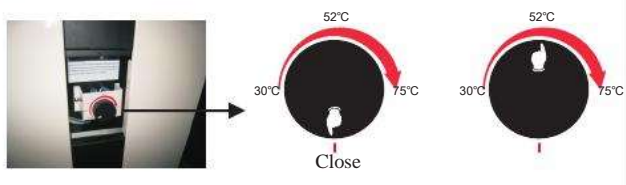
<div style="background-color: black; color: white; padding: 2px; text-align: center; font-weight: bold;">1</div>  <div style="background-color: black; color: white; padding: 2px;">Take off the screw of access door on front panel.</div>	<div style="background-color: black; color: white; padding: 2px; text-align: center; font-weight: bold;">2</div>  <div style="background-color: black; color: white; padding: 2px;">Turn the thermostat knob to set temperature.</div>
--	--

3



Put the access door back and fix it with screw.

	<ul style="list-style-type: none"> ■ This electric heater is set to turn on when water temperature drops to 30°C, in case heat pump capacity is not enough in critical weathers or heat pump fails to work. ■ It can also be set manually to higher temperature when needed. However please always make sure to set it to lower temperature than heat pump set temperature, otherwise the heater will turn on before the heat pump starts to work, and the system will not work efficiently.
---	--

Service and maintenance

1. Attention



- A. The user mustn't change the structure or wiring inside the unit.
- B. The service and maintenance should be performed by qualified and well-trained technician. When the unit fails to run, please cut off power supply immediately.
- C. The smart control system can automatically analyze various protection problems during daily use, and display the failure code on the controller. The unit may recover by itself.
- D. Under normal operation, the pipings inside the unit don't need any maintenance.
- E. Under normal running, the user only needs to clean the surface of the outdoor heat exchanger per month or quarter of a year.
- F. If the unit runs in a dirty or oily environment, please clean the outdoor heat exchanger and heat exchanger by professionals, using specified detergent, to ensure the performance and efficiency of the unit.
- G. Please pay attention to the ambient environment, to check if the unit is installed firmly, or if the air inlet and outlet of the outdoor unit is blocked or not.
- H. Unless the water pump is damaged, no service or maintenance should be done to the water system inside the unit. It's recommended to clean water filter regularly or change it when it's very dirty or blocked.

Service and maintenance

2. Service

2.1 Indoor unit

Service on indoor unit as follows: (this operation must be done by qualified personnel)

1. Cut off the power supply
2. Remove the front panel (Be care about the cables in between)
3. Check the electric part

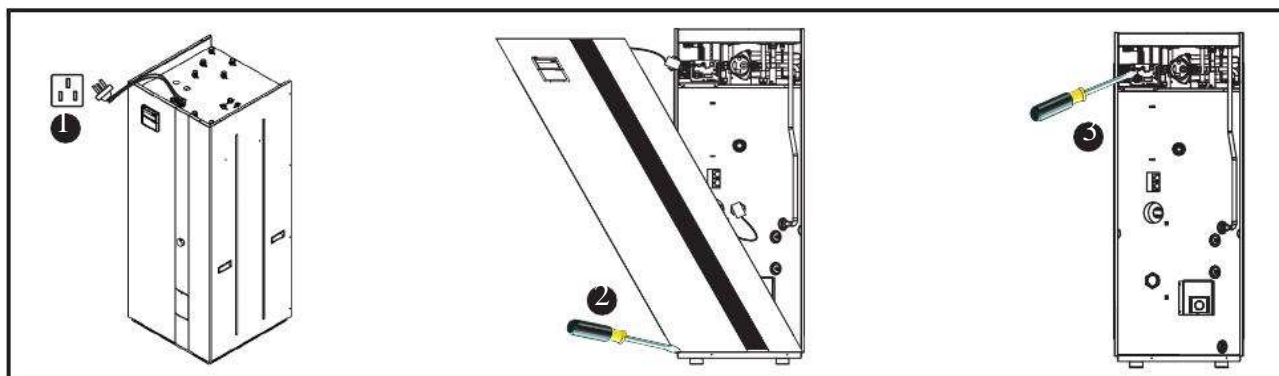

2.2 Outdoor unit

Service on outdoor unit as follows: (this operation must be done by qualified personnel)

1. Cut off the power supply
2. Remove the top cover
3. Take off the electronic box cover
4. Check the electric part

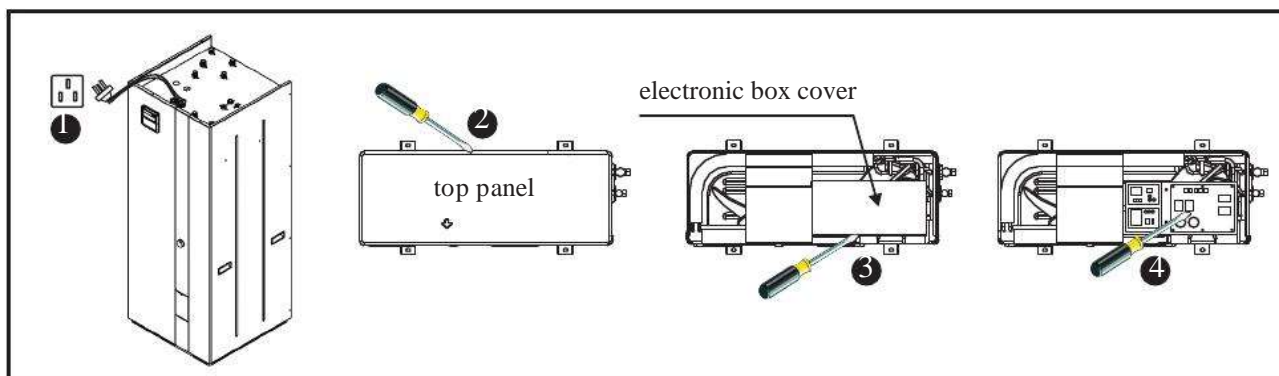

3. Maintenance

3.1 Cleaning of water filter

The water filter should be cleaned according to the manual of water filter, to ensure the water flow of the water system. It is recommended that it be cleaned once in the first month, and then, once half a year.

3.2 Cleaning of heat exchanger

Heat exchanger should be cleaned once half a year, because after long term running, gap between the fins of heat exchanger may be clogged up by dust, leaves, plastic films or papers, which will affect the efficiency of heat exchange, please clean the heat exchanger as follows:

- A. Use a vacuum cleaner to clean the surface of the fins, to get rid of the dust or other rubbish.
- B. Use a soft nylon brush to clean the fins, rinse by water at the same time (please don't rinse with high water pressure). If the outdoor unit is located in an oily place and is hard to clean, please ask for professional service to clean it.
- C. After cleaning, please leave the unit at a shady and well-ventilated environment to dry the surface of the unit.
 - ①. Avoid splashing water to the electric part when cleaning.
 - ②. Avoid touching the sharp fins when cleaning, or they may cut your skin. It's recommended to wear rubber gloves before cleaning.
 - ③. The fins of heat exchanger are soft, please don't wipe strongly with hard object, or it may damage the fins.
 - ④. If the unit is working in a salty environment, please clean the heat exchanger more often.
 - ⑤. If the fins have corrosion in surface, please move the unit to a better environment.

3.3 Gas charging

The refrigerant plays an important role in delivering energy in cooling or heating. Insufficient refrigerant affects directly efficiency of cooling and heating. Please pay attention to the following before adding refrigerant:

- A. The work should be done by professionals
- B. Please make sure the copper pipe has no leakage before gas charging. If the copper pipes has leakage, please repair or change the pipes firstly.
- C. Don't add too much refrigerant than required, or it may cause a lot of failures, such as high pressure and low efficiency.
- D. This system uses R410A refrigerant, whose pressure is about 1.6 times than that of R22, so never use R22 or other refrigerant to replace R410A.
- E. There must be no air in the refrigerant circulation, because the air will cause abnormal high pressure, which will damage the gas piping and lower heating or cooling efficiency.
- F. If the refrigerant leaks in indoor environment, please ventilate the room.

Service and maintenance

G. Copper pipe must be used for gas pipe. Never use iron pipe, aluminium pipe or alloy pipe.

Gas pipes sizes:

Outer dimension (mm)	Thickness (mm)
$\phi 9.52$	0.65
$\phi 12.7$	0.75

3.4 Anti-freezing in Winter

In order to avoid the water inside unit freeze and damage the unit, please don't turn off the unit

very often, keep it working or standby when the ambient temp. is below 0°C.

Service and maintenance

4. Troubleshooting

Failure	Cause	Solution
Unit can't start up	1. No power supply	1. Check the power supply
	2. Fuse is broken or circuit breaker is disconnected	2. Check if it's open circuit or if the motor coil is earthed. Then change a fuse and reset the breaker, check if the circuit is stable or the connection is well.
	3. Some kind of protection works	3. Check which protection is working, and clear the protection, then restart the unit.
	4. Wiring is loose	4. Check the wire connection and tighten the screws on the terminal
	5. compressor fails	5. Change a compressor
Fan fails to run	1. Fan motor wire loose	1. Check the wire connections.
	2. fan motor failure	2. Change fan motor.
Low heating performance	1. The coil fins are very dirty	1. Clean the evaporator coil
	2. Air inlet is blocked	2. Remove any object that blocks the air circulation of the unit.
	3. Insufficient of refrigerant	3. Inspect the unit for leakage and fix it if any. Discharge all refrigerant and charge the unit again with correct amount.
Too high noise from the water pump, or no water flow when the water pump is running	1. Lacking of water in water system	1. Check the water filling device. Fill the system with enough water.
	2. Air exists in water system	2. Purging the air out.
	3. Valves in water system are not completely opened	3. Check all the valves to ensure they are fully opened.
	4. Water filter is dirty or blocked	4. Clean the water filter
Too high compressor discharge pressure	1. Too much refrigerant	1. Discharge all refrigerant and charge the unit again with right amount.
	2. Air exists in refrigeration system	2. Discharge all refrigerant and charge the unit again with right amount.
	3. Inadequate water flow	3. Check the water flow of the system. Use a bigger pump to increase the water flow if necessary.
	4. Too high water temperature	4. Check the value of the water temperature sensor, to ensure it works properly.
Too low suction pressure	1. Drier filter is blocked	1. Change a new one
	2. Electronic expansion valve is not opened	2. Repair or change a new one
	3. Leakage of refrigerant	3. Inspect the unit for leakage and fix it if any. Discharge all refrigerant and charge the unit again with right amount.
Unit can not defrost properly	1. Coil temperature sensor failure	1. Check the position and value of the coil temperature sensor. Replace it if necessary.
	2. Air inlet/outlet is blocked	2. Remove any object that blocks the air circulation of the unit. Clean the evaporator coil occasionally.

Service and maintenance

The following phenomenon may not be problems of unit itself.
Please contact with a professional maintenance staff for help.

Number	Failure	Solution
1	The unit is not running	When the unit restarts, the compressor will start 3 minutes later (self-protection of compressor), please check if the circuit breaker is disconnected, and if there is normal power supply for the wire controller.
2	Low capacity	Check if the air inlet or outlet is blocked in outdoor unit; check if the setting temperature is too high in cooling mode, or too low in heating mode.

Wiring diagram

【6KW Indoor unit】

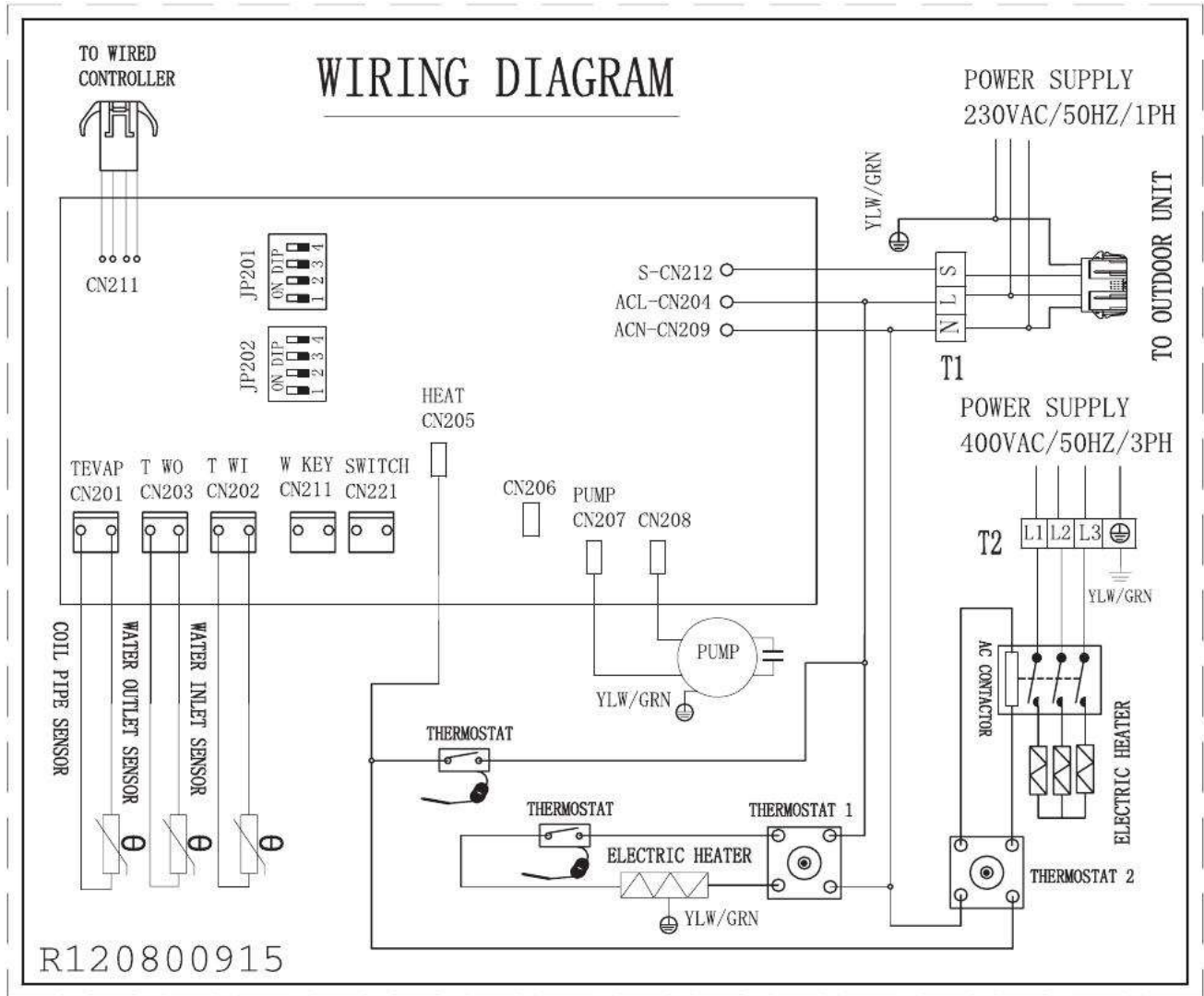

TAKE CARE!

This diagram is subject to change with improvement of the unit. Always refer to the diagram supplied with the product.

Wiring diagram

【9KW Indoor unit】

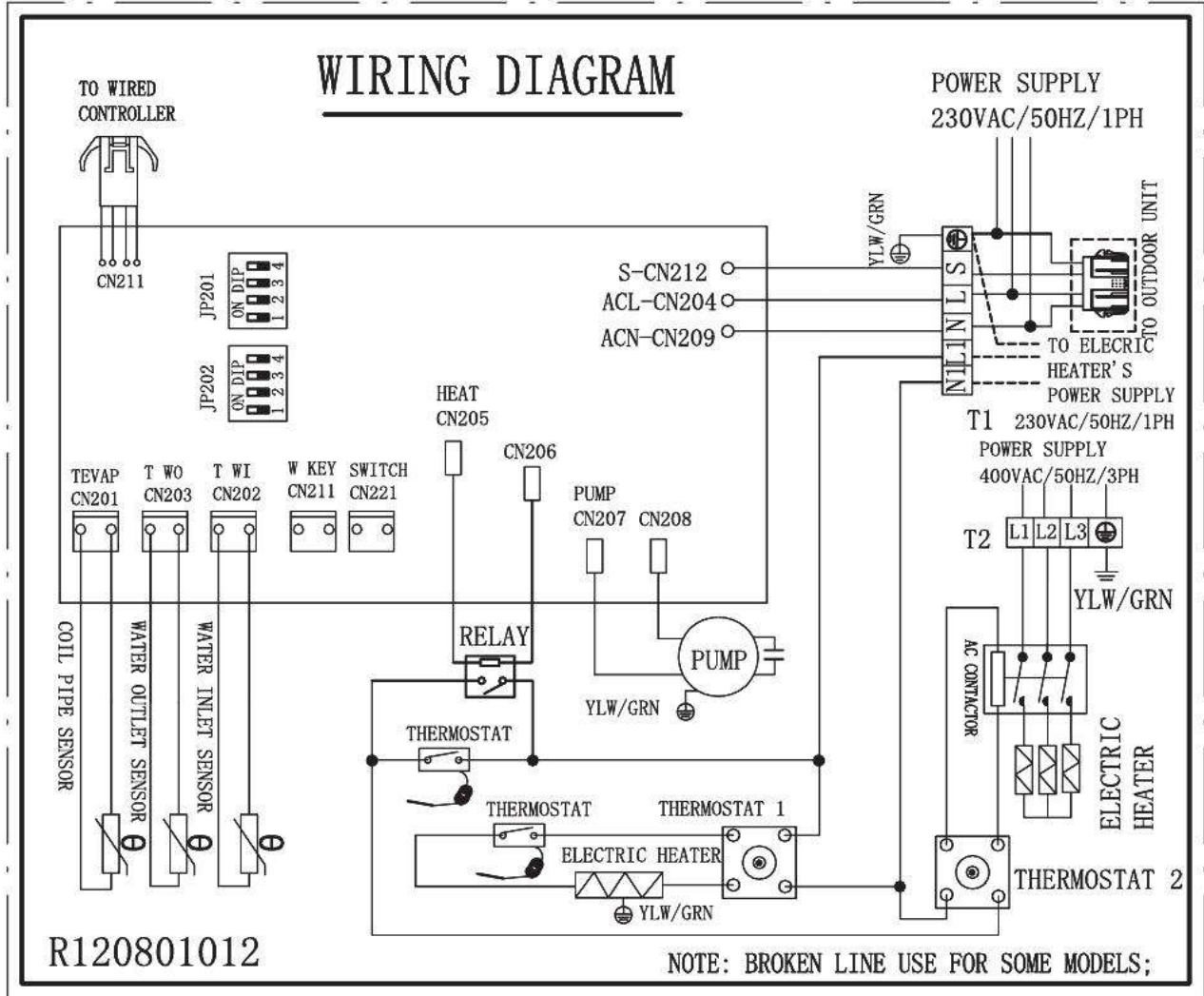

TAKE CARE!

This diagram is subject to change with improvement of the unit. Always refer to the diagram supplied with the product.

Wiring diagram

【6KW Outdoor unit】

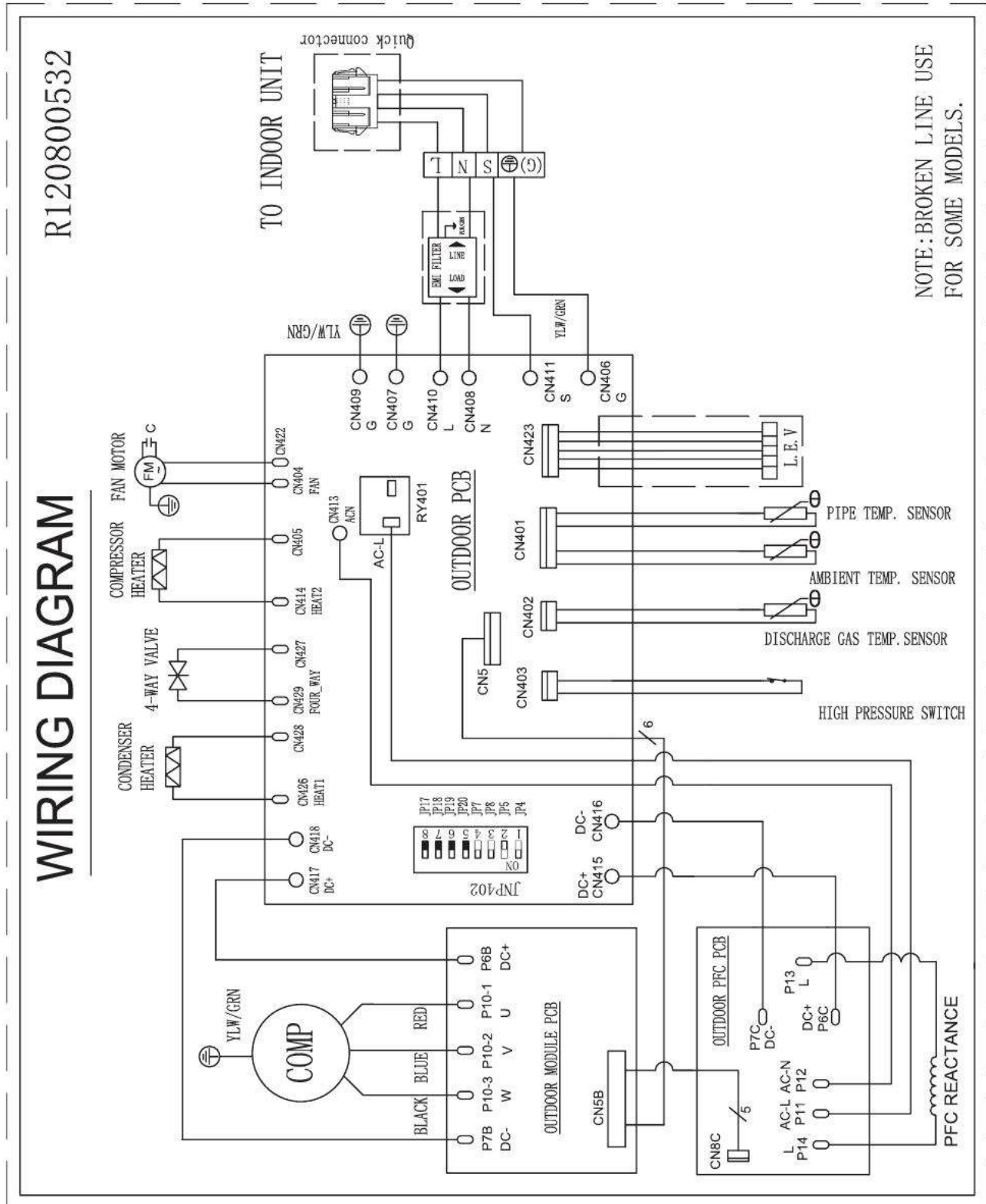

TAKE CARE!

This diagram is subject to change with improvement of the unit. Always refer to the diagram supplied with the product.

Wiring diagram

【9KW Outdoor unit】

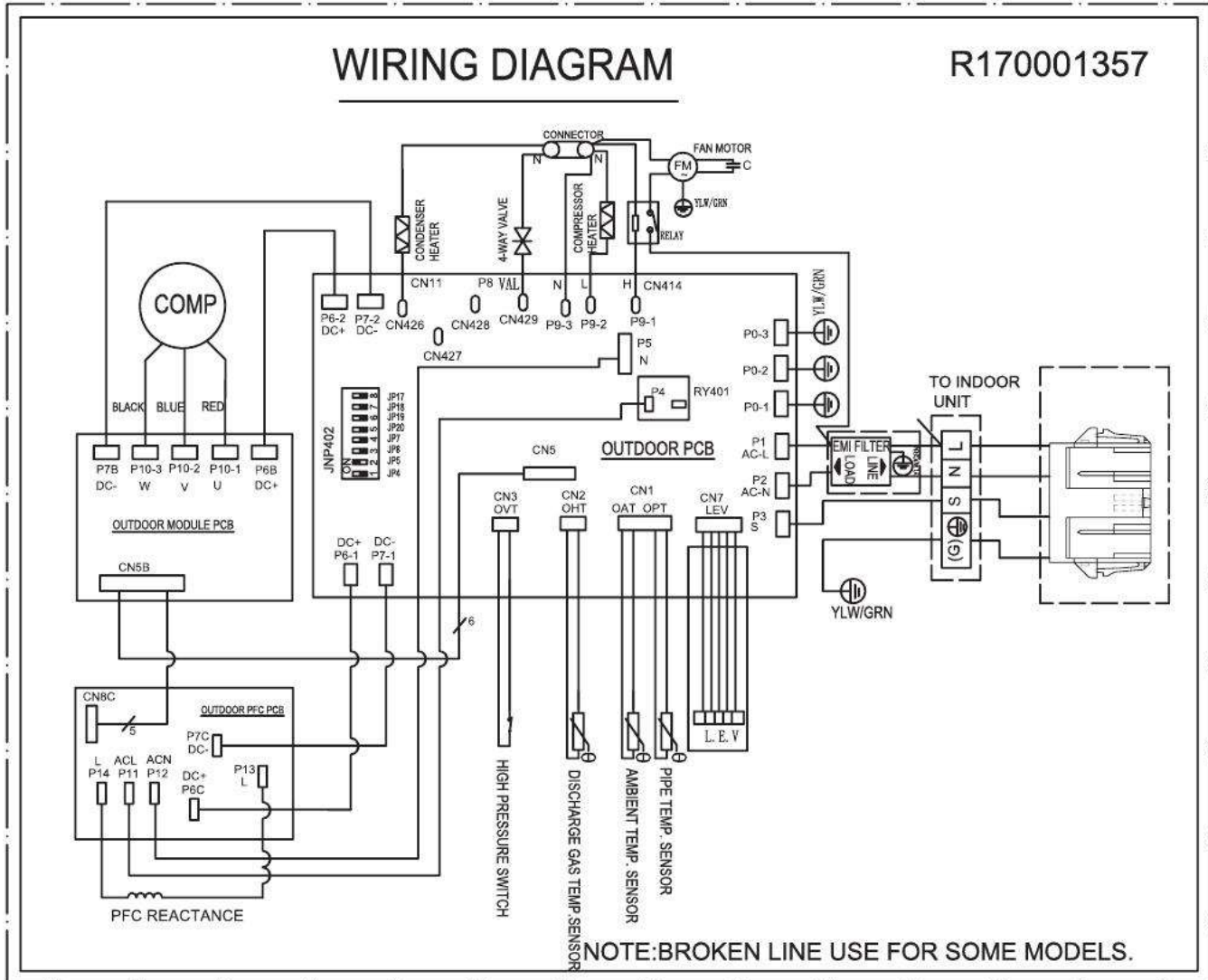

TAKE CARE!

This diagram is subject to change with improvement of the unit. Always refer to the diagram supplied with the product.

THANK YOU FOR CHOOSING US

R120400425-V1.0